

Long hole drilling tools

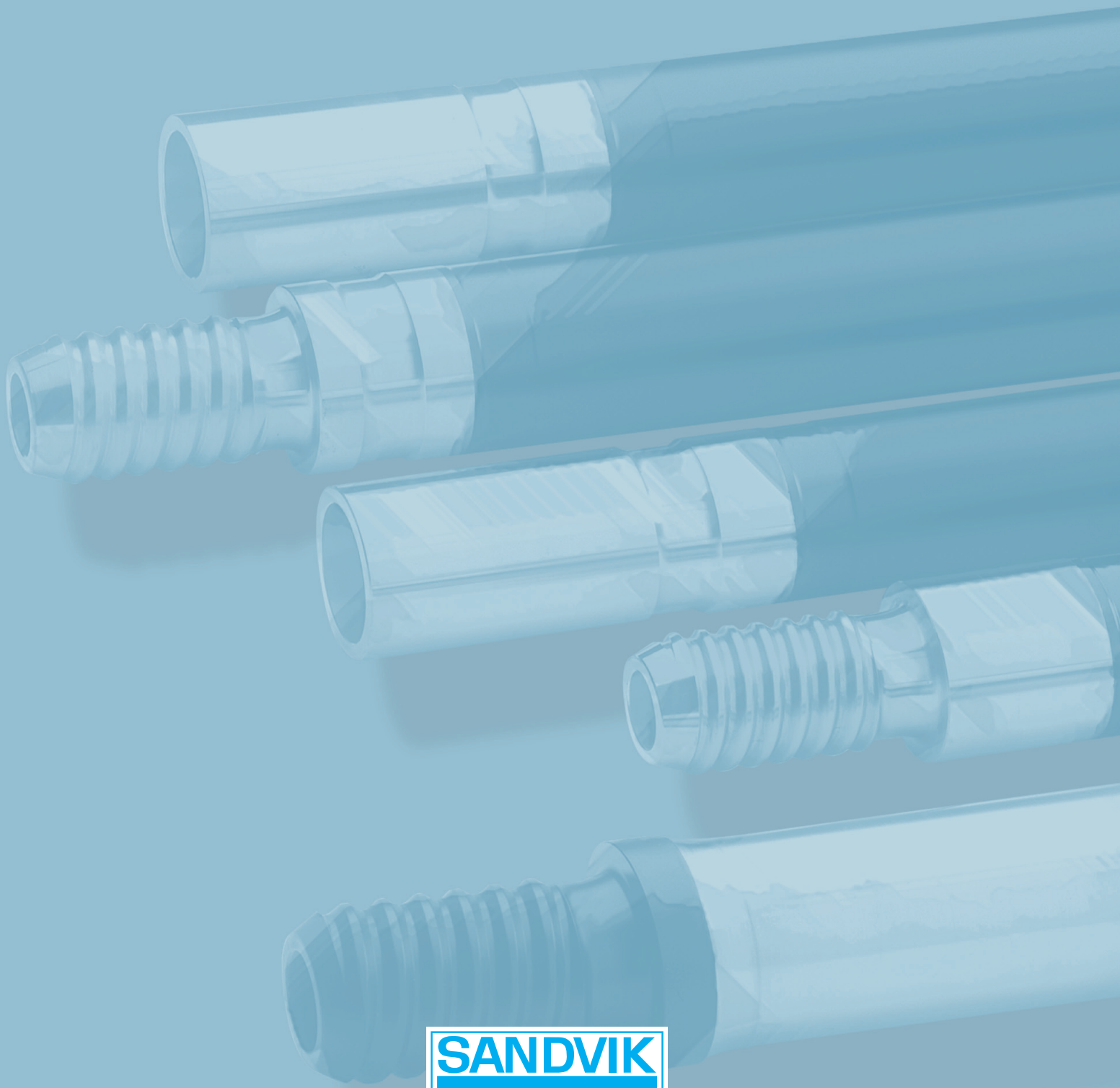

SANDVIK

Long hole drilling underground

S T R E T N O G

Page

Extension drilling tools, R32	57
Extension drilling tools, T35	59
Extension drilling tools, T38	60
Extension drilling tools, T45	63
Extension drilling tools, T51	65
Tube drilling tools, T45	67
Tube drilling tools, ST58	68
Tube drilling tools, ST68	70

Long hole drilling underground

R32 (1 1/4") for 51 - 57 mm holes (2"-2 1/4")

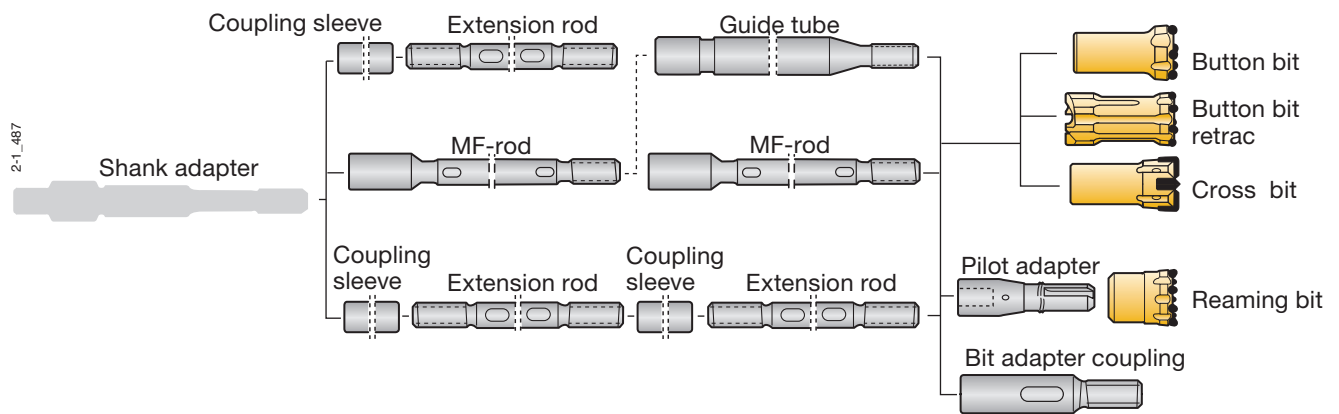

Flushing hole, mm		Buttons, mm		Angle	Dimensions		Bit classification	Part No.
Front	Gauge	Front	Gauge		D			
No	No	No	No		mm	in		

Button bit



3x6	—	3x9	6x10	35°	51	2"	HMCVA	7733-5351-S45
3x6	—	3x9	6x10	35°	51	2"	MSCAN	7733-5351-R45
3x6	—	3x10	6x11	35°	57	2 1/4"	HMCVA	7733-5357C-S45

Button bit, Retrac



3x6	—	3x9	6x10	30°	51	2"	HMCFVA	7733-7851-S45
3x6	—	3x9	6x10	30°	51	2"	HMCFV	7733-7851-S65
3x6	—	3x9	6x10	30°	51	2"	MSCFAN	7733-7851-R45

Button bit



3x6	—	3x9	6x10	35°	51	2"	SCFN	7733-5751C-C55
3x6	—	3x10	6x10	40°	57	2 1/4"	SCFN	7733-5757C-C55

Cross bit



1x5	2x7.5	—	—	—	51	2"	—	7733-1451-42
1x5	2x7.5	—	—	—	57	2 1/4"	—	7733-1057-42

Dimensions			Part No.	
L		D		
mm	ft	in	mm	in

Guide Tube

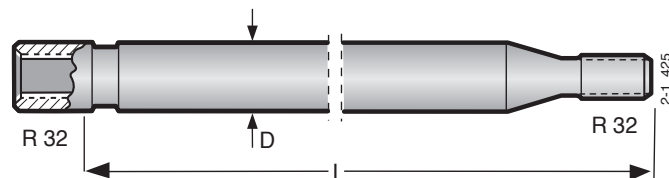

1830	6'	—	46	1 3/4"	7953-4618-20
------	----	---	----	--------	--------------

Female end OD 46 mm.

MF-rod, R32 - Round 32 - R32

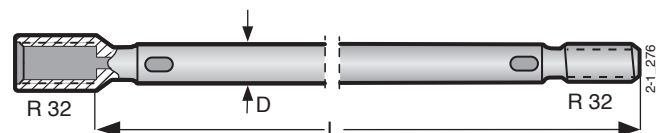

915	3'	—	32	1 1/4"	7853-5109-20
1220	4'	—	32	1 1/4"	7853-5112-20
1525	5'	—	32	1 1/4"	7853-5115-20
1830	6'	—	32	1 1/4"	7853-5118-20

Flushing hole Ø 9.2 mm. Wrench flat 25.4 mm.
Female end OD 45 mm.

Long hole drilling underground

R32 (1 1/4") for 51 - 57 mm holes (2"-2 1/4")

	Dimensions					Part No.
	L			D		
	mm	ft	in	mm	in	
Extension rod, R32 - Round 32 - R32	915	3'	-	32	1 1/4"	7853-3309-20
	1220	4'	-	32	1 1/4"	7853-3312-20

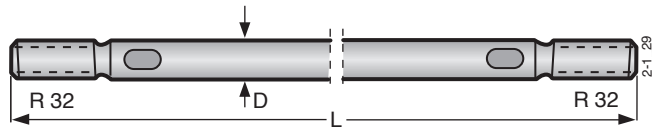

Flushing hole Ø 11.7 mm. Wrench flat 25.4 mm.

Coupling sleeve R32

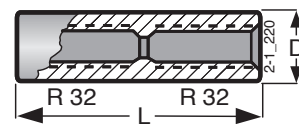

150	-	5 29/32"	44	1 47/64"	7993-3644
-----	---	----------	----	----------	-----------

Bit adapter coupling, R32 -Thread

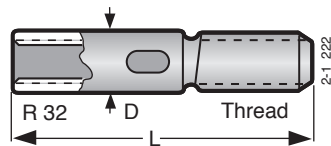

Wrench flat 38 mm.

Thread	L	ft	in	D	Part No.
R38	225	-	8 55/64"	45	1 49/64" 7833-4301
T38	225	-	8 55/64"	45	1 49/64" 7833-4401

Reduction coupling, R32 - Thread

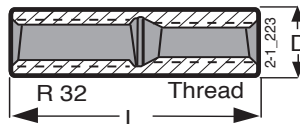

Thread	L	ft	in	D	Part No.
R25	160	-	6 1/4"	43	1 11/16" 7993-2443
R28	165	-	6 1/4"	44	1 47/64" 7993-0444
R38	170	-	6 11/16"	55	2 5/32" 7994-3455
T38	195	-	7 11/16"	55	2 5/32" 7314-3555

Pilot adapter for reaming of 51 mm (2") pilot holes

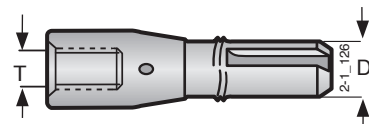

Thread	L	ft	in	D	Part No.
R32	-	-	-	47	1 7/8" 7823-3647

Reaming bit

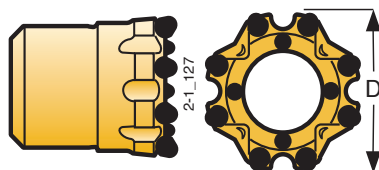

Buttons, mm	Front No	Gauge Size	Angle	Dimensions		Bit classification	Part No.
				D mm	in		
4x12	8x12	35°	102	4"	-	7723-4802-S45	
4x12	8x12	35°	115	4 1/2"	-	7723-4815-S45	
4x12	8x12	35°	127	5"	-	7723-4827-S45	

Shank adapter



See page 87

Long hole drilling underground

T35 (1 3/8") bit thread for 54 - 57 mm holes (2 1/8" - 2 1/4")

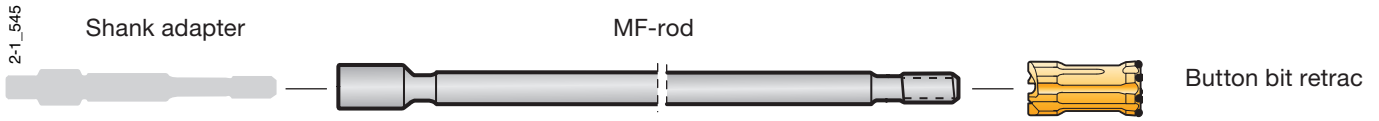

	Flushinghole, mm		Buttons, mm			Dimensions		Bit classification	Part No.
	Front No Size	Gauge No Size	Front No Size	Gauge No Size	Angle	D mm	in		
Button bit, Retrac T35									
	3x6	—	3x9	6x11	35°	54	2 1/6"	MSCFAN	7517-7854-R45
	3x6	—	3x10	6x11	35°	57	2 1/4"	MSCFAN	7517-7857-R45

Button bit									
	3x6	1x5	3x9	6x11	35°	54	2 1/8"	MSCFAN	7517-5354A-S45

	Dimensions		D		Part No.
	L mm	ft	mm	in	
MF-rod, T35 - Round 39 - T35					
	1830	6'	39	1 1/2"	7327-4718-20

Female end OD 48,2 mm.

Shank adapter									

See page 87

Long hole drilling underground

T38 (1 1/2") for 64 - 70 mm holes (2 1/2" - 2 3/4")

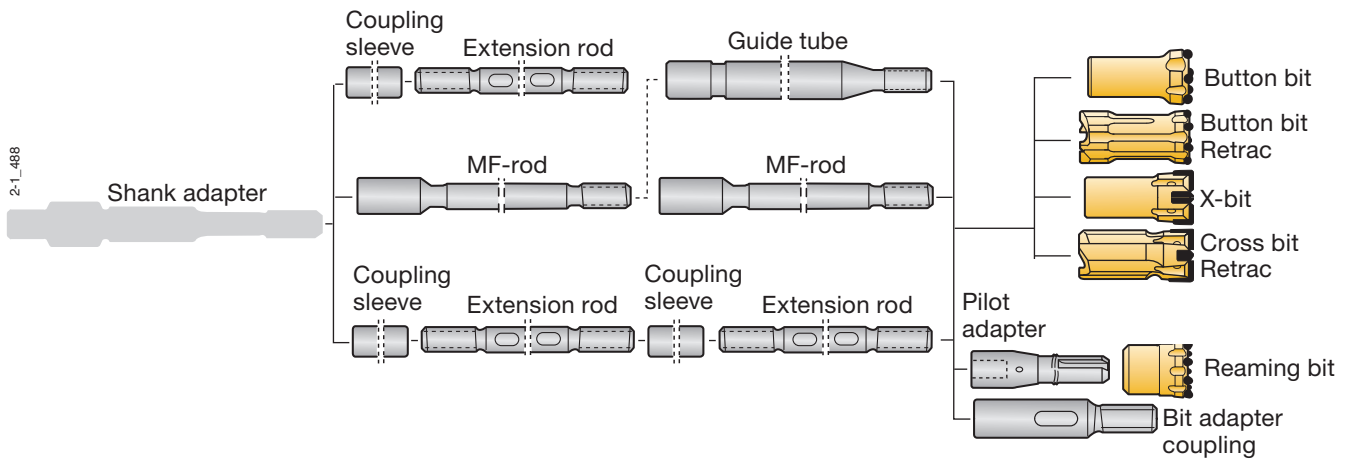

Flushinghole, mm		Buttons, mm		Angle	Dimensions		Bit classification	Part No.
Front No	Gauge Size	Front No	Gauge Size		D mm	in		

Button bit

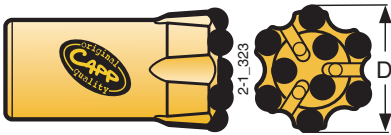

3x7	-	3x11	6x12	30°	64	2 1/2"	HMCVA	7514-3864-S45
3x7	-	3x11	6x12	30°	64	2 1/2"	HMCVA	7514-3864-S65

Button bit, Drop Center



3x8.0	-	4x9	6x10	35°	64	2 1/2"	HMCVA	7514-5964-S45
-------	---	-----	------	-----	----	--------	-------	---------------

Button bit, Retrac

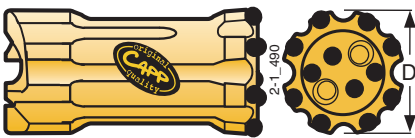

2x11	-	4x10	8x10	30°	64	2 1/2"	HMCFVA	7514-7864-S45
------	---	------	------	-----	----	--------	--------	---------------

Button bit, Retrac



2x11	-	6x10	8x10	35°	70	2 3/4"	HMCFVA	7514-7870-S45
------	---	------	------	-----	----	--------	--------	---------------

Button bit, Retrac, Drop Center



3x8	-	4x9	6x10	35°	64	2 1/2"	HMCFVA	7514-7964-S45
3x8	-	4x9	6x10	40°	64	2 1/2"	MSCFAN	7514-7964-R45
3x8	-	4x9	6x10	40°	64	2 1/2"	MSCFAN	7514-7964-R55

Long hole drilling underground

T38 (1 1/2") for 64 - 70 mm holes (2 1/2" - 2 3/4")

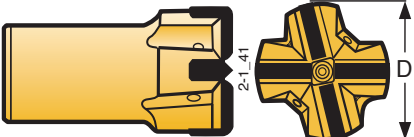
	Flushinghole, mm		Buttons, mm			Dimensions		Bit classification	Part No.
	Front No	Gauge Size	Front No	Gauge Size	Angle	D mm	in		
X-bit									
	1x7.5	2x7.5	-	-	-	64	2 1/2"	-	7514-4064-11

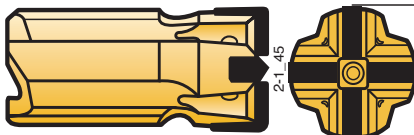
Cross bit, Retrac									
	1x7.5	2x7.5	-	-	-	64	2 1/2"	-	7514-8064-11

	Dimensions			D		Part No.
	L mm	ft	in	mm	in	

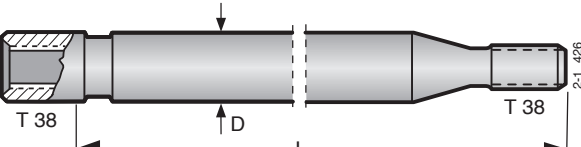
Guide tube									
	1830	6'	-	56	2 13/64"	7955-5618-20			
Female end OD 56 mm.									

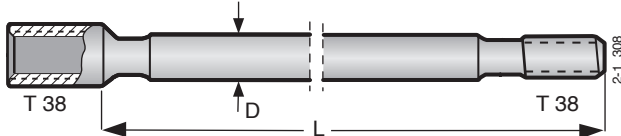
MF-rod, T38 - Round 39 - T38									
	1220	4'	-	39	1 1/2"	7324-4712C-20			
	1525	5'	-	39	1 1/2"	7324-4715C-20			
	1830	6'	-	39	1 1/2"	7324-4718C-20			
Flushing hole Ø 14.5 mm. Female end OD 56 mm.									

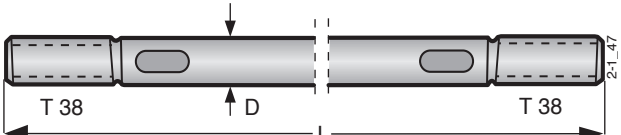
Extension rod, T38 - Round 39 - T38									
	1220	4'	-	39	1 1/2"	7324-4312C-20			
	1830	6'	-	39	1 1/2"	7324-4318C-20			
Flushing hole Ø 14.5 mm. Wrench flat 32 mm.									

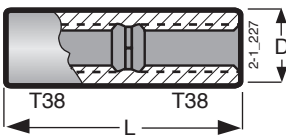
Coupling sleeve									
	191	-	7 1/2"	55	2 5/32"	7314-3355			

Long hole drilling underground

T38 (1 1/2") for 64 - 70 mm holes (2 1/2" - 2 3/4")

	Dimensions			D		Part No.
	L			mm	in	
	mm	ft	in			

Bit adapter coupling, T38 - Thread

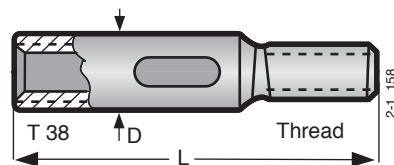

Wrench flat 44.5 mm.

Thread	L			D		Part No.
R32	270	-	10 41/64"	57	2 1/4"	7334-3301
R38	280	-	11 1/32"	57	2 1/4"	7334-4301
T45	285	-	11 7/32"	57	2 1/4"	7334-5401

Reduction coupling, T38 -Thread

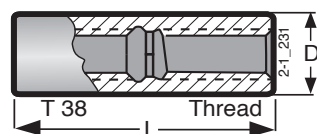

Thread	L			D		Part No.
R32	195	-	7 11/16"	55	2 5/32"	7314-3555
R38	185	-	7 9/32"	55	2 5/32"	7314-4455
T45	220	-	8 21/32"	61	2 3/8"	7314-6261

Pilot adapter for reaming of 51 mm (2") pilot holes

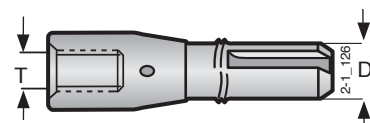

Thread	L			D		Part No.
T38	-	-	-	47	1 7/8"	7823-2647

	Buttons, mm		Angle	Dimensions		Bit classification	Part No.
	Front No	Gauge Size		D	in		

Extension reaming equipment, Reaming bit

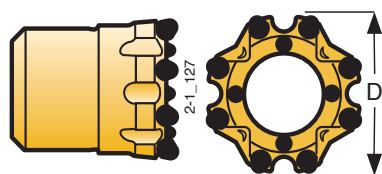

4x12	8x12	35°	102	4"	-	7723-4802-S45
4x12	8x12	35°	115	4 1/2"	-	7723-4815-S45
4x12	8x12	35°	127	5"	-	7723-4827-S45

Shank adapter



See page 87

Long hole drilling underground

T45 (1 3/4") for 76 mm holes (3")

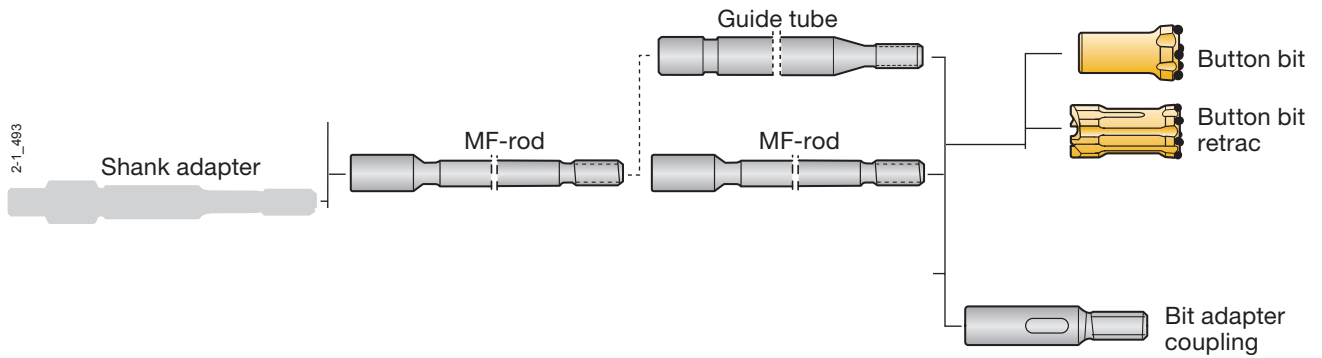

Flushinghole, mm		Buttons, mm		Angle	Dimensions		Bit classification	Part No.
Front	Gauge	Front	Gauge		D	in		

Button bit

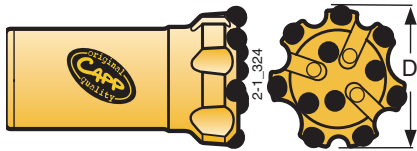

3x9	—	4x11	7x12	35°	76	3"	HMCVA	7515-3876-S45
3x9	—	4x11	7x12	35°	76	3"	HMCV	7515-3876-S65

Button bit, Drop Center

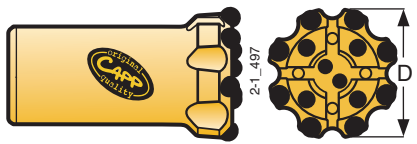

7.0	—	6x10	8x11	30°	76	3"	HMCVA	7515-5976-S45
-----	---	------	------	-----	----	----	-------	---------------

Button bit, Retrac



2x12	—	6x10	8x11	35°	76	3"	HMCFVA	7515-7876-S45
2x12	—	6x10	8x11	35°	76	3"	HMCV	7515-7876-S65

Button bit, Retrac, Drop Center

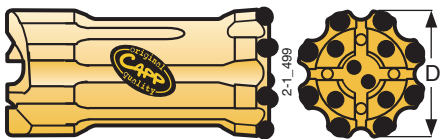

4x7	—	6x10	8x11	30°	76	3"	HMCFVA	7515-7976-S45
4x7	—	6x10	8x11	35°	76	3"	MSCFAN	7515-7976-R45
4x7	—	6x10	8x11	35°	76	3"	MSCFAN	7515-7976-R55

Long hole drilling underground

T45 (1 3/4") for 76 mm holes (3")

	Dimensions			D		Part No.
	L			mm	in	

Guide tube

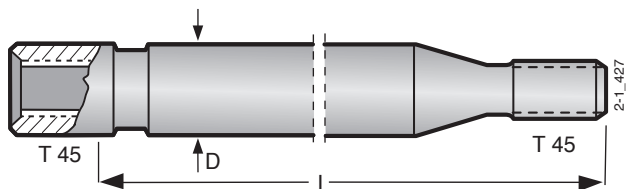

Female end OD 63 mm / 76 mm.

1830	6'	–	63	2 31/64"	7956-6318-21
------	----	---	----	----------	---------------------

MF-rod T45 - Round 46 - T45

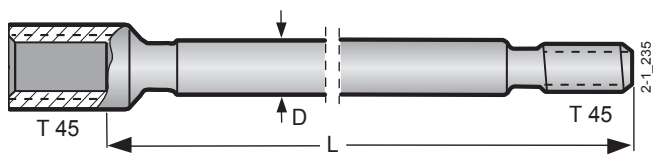

Flushing hole Ø 17 mm. Female end OD 63 mm.

1525	5'	–	46	1 3/4"	7325-7715C-20
1830	6'	–	46	1 3/4"	7325-7718C-20

Bit adapter coupling, T45 -Thread

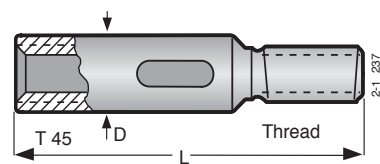

Wrench flat W

	Thread						
W=38	T38	265	–	10 7/16"	63	2 31/64"	7335-4401
W=44.5	T51	285	–	11 7/32"	63	2 31/64"	7335-6401

Shank adapter



See page 87

Long hole drilling underground

T51 (2") for 89 mm holes (3 1/2")

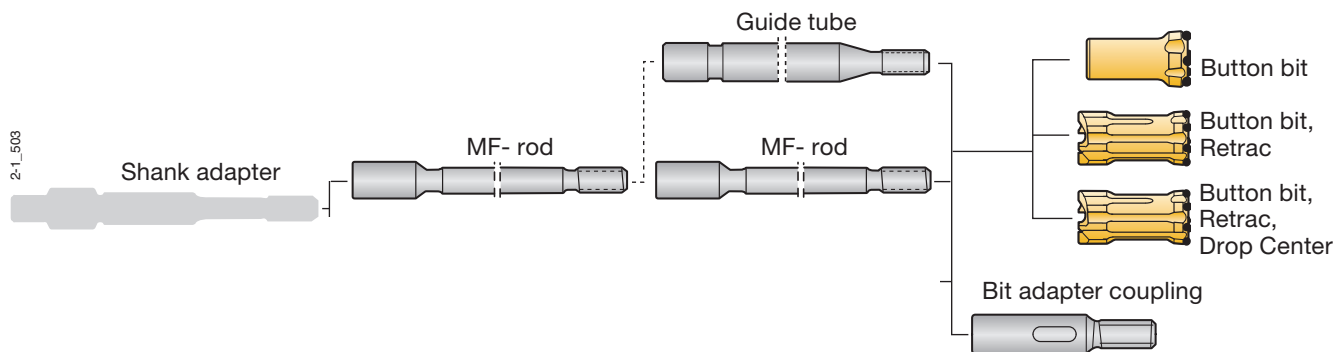

Flushinghole, mm		Buttons, mm		Angle	Dimensions		Bit classification	Part No.
Front	Gauge	Front	Gauge		D	in		

Button bit

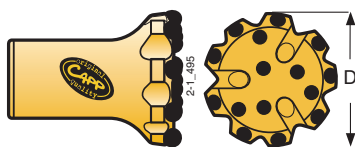

3x12	—	6x10	9x11	35°	89	3 1/2"	HMCVA	7516-2689-S45
------	---	------	------	-----	----	--------	-------	---------------

Button bit, Drop Center

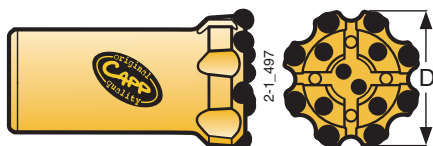

4x10	—	6x11	8x12	35°	89	3 1/2"	HMCVA	7516-5989-S45
------	---	------	------	-----	----	--------	-------	---------------

Button bit, Retrac

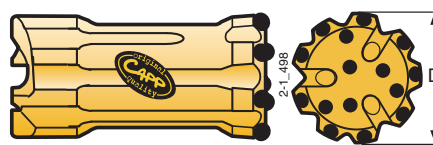

3x12	—	6x10	9x11	35°	89	3 1/2"	HMCFVA	7516-7889-S45
------	---	------	------	-----	----	--------	--------	---------------

Button bit, Retrac, Drop Center



4x10	—	6x11	8x12	35°	89	3 1/2"	HMCFVA	7516-7989-S45
4x10	—	7x11	8x12	40°	89	3 1/2"	MSCFAN	7516-7989-R45
4x10	—	7x11	8x12	40°	89	3 1/2"	MSCFAN	7516-7989-R55

Long hole drilling underground

T51 (2") for 89 mm holes (3 1/2")

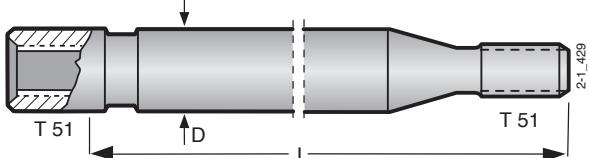
	Dimensions			D		Part No.
	L			mm	in	
mm	ft	in				
Guide tube						
	1830	6'	–	76	3"	7957-7618-20
Female end OD 76 / 87 mm.						

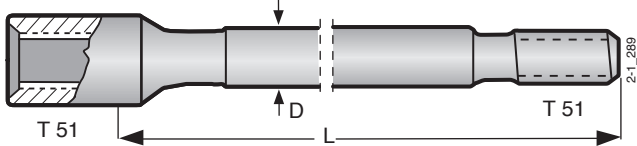
MF-rod, T51 - Round 52 - T51						
	1830	6'	–	52	2"	7326-5518C-20
Flushing hole Ø 21.5 mm. Female end OD 71 mm.						

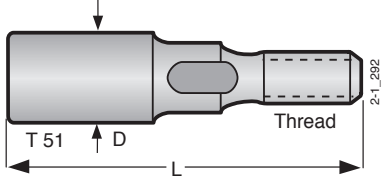
Bit adapter coupling, T51 - Thread						
	Thread					
T45	285	–	11 7/32"	71	2 51/64"	7336-5401
Wrench flat 44.5						

Shank adapter						
	See page 87					

Long hole drilling underground

Tube drilling tools T45 (1 3/4") for 76 mm holes (3")

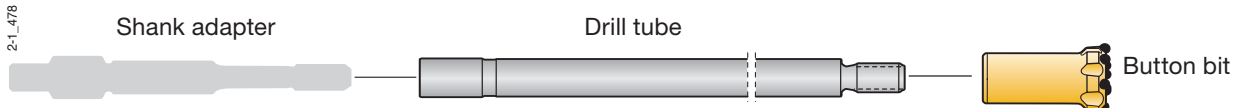

	Flushinghole, mm		Buttons, mm		Angle	Dimensions D		Bit classification	Part No.
	Front No Size	Gauge No Size	Front No Size	Gauge No Size		mm	in		

Button bit, XDC

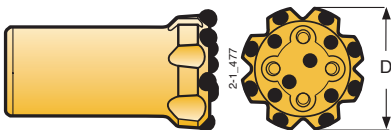

4x7.5	—	6x10	8x11	35°	76	3"	HMCVA	7525-8476-R65
4x10	—	6x12	8x12	35°	89	3 1/2"	HMCVA	7525-8489-R65

Button bit, Heavy Duty

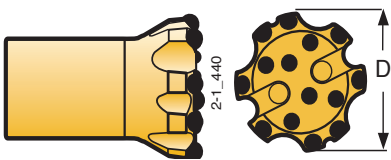

2x12	—	4x11	8x12	35°	76	3"	HCV	7525-6976-S65
2x14	—	4x12	8x13	35°	89	3 1/2"	HCV	7525-6989-S65

	Dimensions L			D		Part No.
	mm	ft	in	mm	in	

Drill tube, T45 - Round 65 - T45

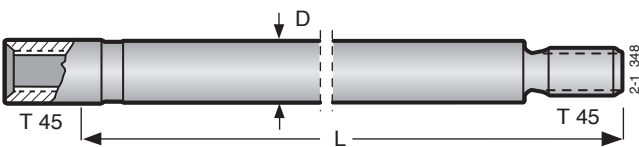

1525	5'	—	65	2 1/2"	7985-6315-26
1830	6'	—	65	2 1/2"	7985-6318-26

Flushing hole Ø 18 mm.

Shank adapter



See page 87

Long hole drilling underground

Tube drilling tools ST58 (2 1/4") for 89 mm holes (3 1/2")

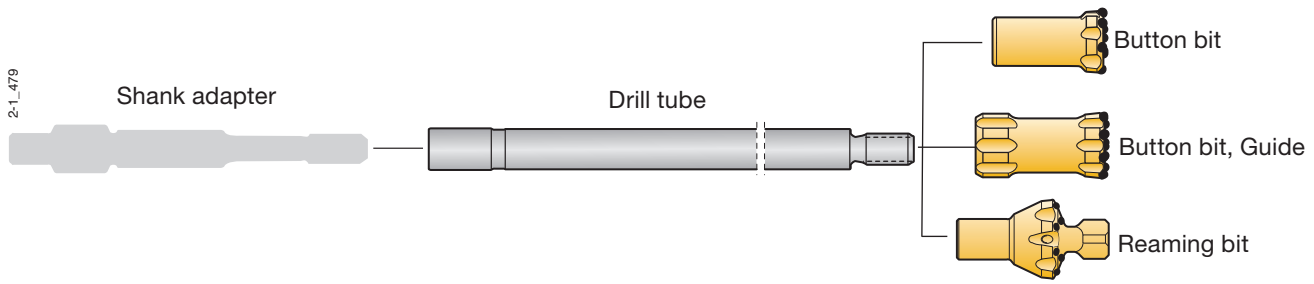

Flushinghole, mm		Buttons, mm		Angle	Dimensions		Bit classification	Part No.
Front No Size	Gauge No Size	Front No Size	Gauge No Size		D mm	in		

Button bit, XDC

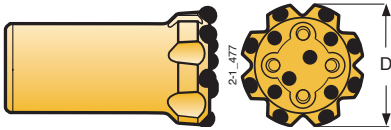

4x10	—	6x12	8x12	35°	89	3 1/2"	HMCVA	7528-8489-R65
------	---	------	------	-----	----	--------	-------	---------------

Button bit, Heavy Duty

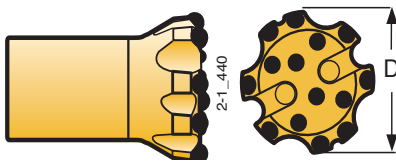

2x14	—	6x12	8x13	35°	89	3 1/2"	HCV	7528-6989-S65
------	---	------	------	-----	----	--------	-----	---------------

Button bit, Guide XDC

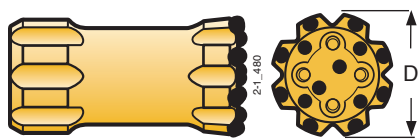

4x10	—	6x12	8x12	35°	89	3 1/2"	HMFVA	7528-7389-R65
------	---	------	------	-----	----	--------	-------	---------------

Buttons, mm		Angle	Dimensions		Bit classification	Part No.
Front No Size	Gauge No Size		D mm	D1 mm		

Reaming bit

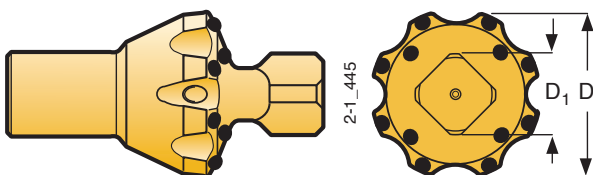

4x14	8x14	35°	152	76	—	7528-5652-S65
------	------	-----	-----	----	---	---------------

Long hole drilling underground

Tube drilling tools ST58 (2 1/4") for 89 mm holes (3 1/2")

	Dimensions			D		Part No.
	L			mm	in	
mm	ft	in				
Drill tube, ST58 - Round 76 - ST58						
1525	5'	–	76	3"		7378-7615-26
1830	6'	–	76	3"		7378-7618-26

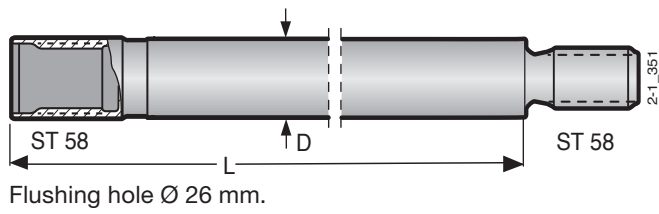

Shank adapter



See page 87

Long hole drilling underground

Tube drilling tools ST68 (2 3/4") for 102-115 mm holes (4" - 4 1/2")

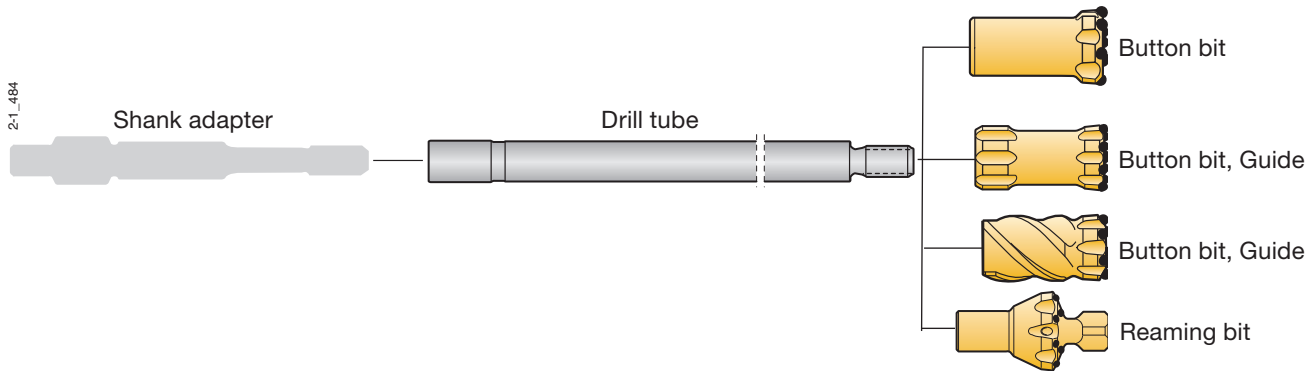

Flushinghole, mm		Buttons, mm		Dimensions D mm in	Bit classi- fication	Part No.
Front	Gauge	Front	Gauge			

Button bit, XDC

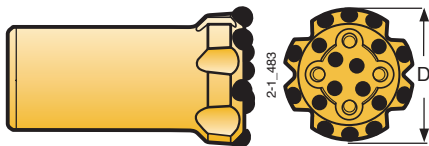

4x10	—	8x12	10x12	35°	102 4"	HMCVA	7529-8402-R65
4x10	—	8x14	10x14	35°	115 4 1/2"	HMCVA	7529-8415-R65

Button bit, Heavy Duty

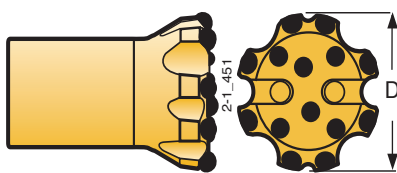

2x15	—	6x14	8x14	35°	102 4"	HCV	7529-6902-S65
2x15	—	6x14	8x16	35°	115 4 1/2"	HCV	7529-6915-S65

Button bit, Guide XDC

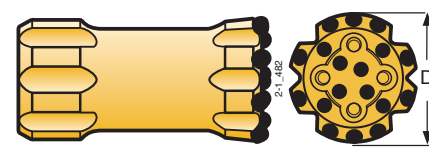

4x10	—	8x12	10x12	35°	102 4"	HMCVA	7529-7302-R65
4x10	—	8x14	10x14	35°	115 4 1/2"	HMCVA	7529-7315-R65

Button bit, Spiral Guide XDC

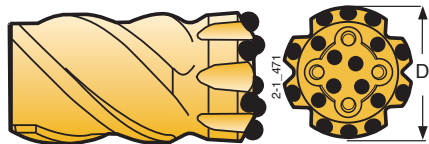

4x10	—	8x12	10x12	35°	102 4"	HMFVA	7529-7302E-R65
------	---	------	-------	-----	--------	-------	----------------

Collaring bit

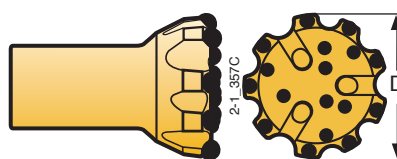

3x18	—	8x16	9x16	35°	152 6"	—	7529-6652-S45
------	---	------	------	-----	--------	---	---------------

Long hole drilling underground

Tube drilling tools ST68 (2 3/4") for 102-115 mm holes (4" - 4 1/2")

Reaming bit

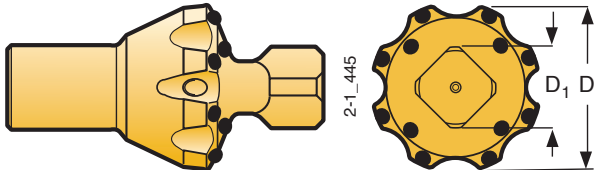

Buttons, mm			Dimensions		Bit classification	Part No.
Front No	Gauge Size	Angle	D mm	D1 mm		
3x16	9x16	35°	152	95	—	7529-5652C-S65
4x14	8x14	35°	152	102	—	7529-5652-S65
4x14	16x14	35°	204	137	—	7529-5604A-S65

Drill tube, ST68 - Round 87 - ST68

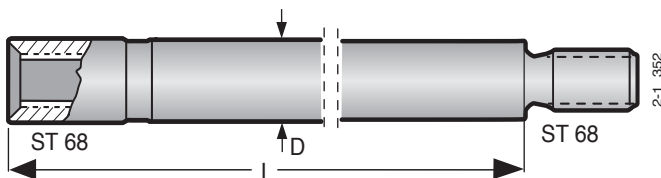

Dimensions				D		Part No.
L mm	ft	in	mm	in		
1525	5'	—	87	3 1/2"	7379-8715-26	
1525	5'	—	87	3 1/2"	7379-8715-46 ¹⁾	
1830	6'	—	87	3 1/2"	7379-8718-26	
1830	6'	—	87	3 1/2"	7379-8718-46 ¹⁾	

FLushing hole Ø 30 mm.

¹⁾ Permanent back flow valve.

Shank adapter



See page 87