

Foundation drilling tools



SANDVIK

Foundation drilling tools

S

Page

Overburden drilling tools, OD72 75

T

Overburden drilling tools, OD92 78

N

Eccentric drilling tools, Tubex 76/127 81

E

Eccentric drilling tools, Tubex XL90/115 84

T

N

O

G

Foundation drilling tools

OD 72 (3 1/2"), for BBE 56/57

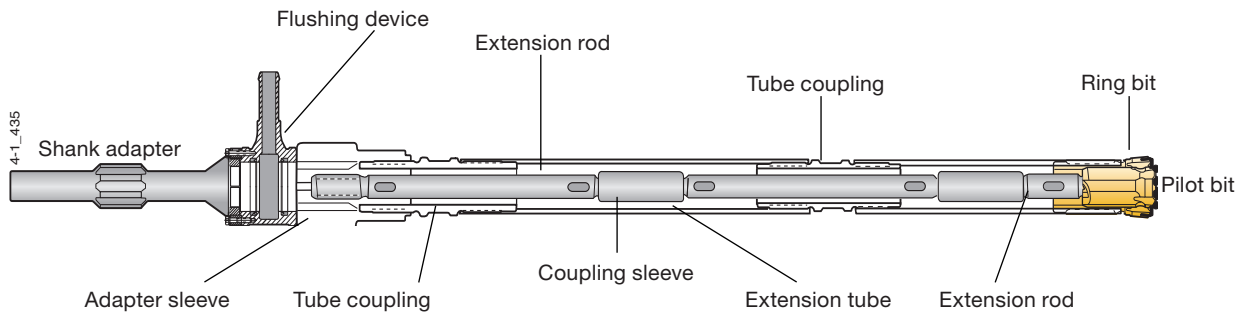

Flushinghole, mm		Buttons, mm			Dimensions		Part No.
Front No	Gauge Size	Front No	Gauge Size	Angle	D mm	in	

Pilot bit, R38, button bit

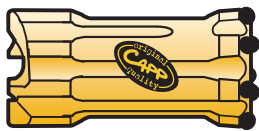

2x11	2x6	4x10	8x10	35°	70	2 3/4"	7734-7870A2-R55
------	-----	------	------	-----	----	--------	-----------------

Pilot bit, R38, x-bit



1x6	4x7.5	-	-	-	70	2 3/4"	7734-4070-11
-----	-------	---	---	---	----	--------	--------------

Ring bit, C89

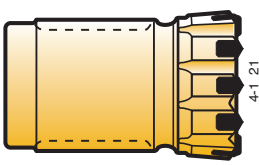

-	-	-	-	-	107	4 7/32"	7588-6108-42
---	---	---	---	---	-----	---------	--------------

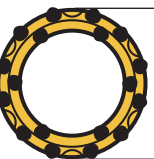
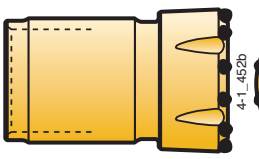

-	-	5x10	10x10	35°	110	4 21/64"	7588-9510-R55
---	---	------	-------	-----	-----	----------	---------------

Dimensions L			D		Part No.
mm	ft	in	mm	in	

Extension tube

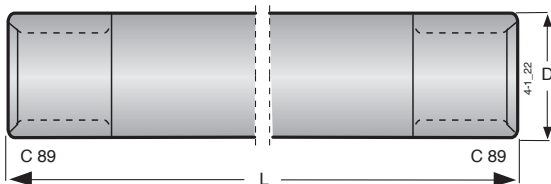

1120	3'	8 1/8"	103	4 1/16"	7985-6012
2950	9'	8 1/8"	103	4 1/16"	7985-6031

Tube coupling

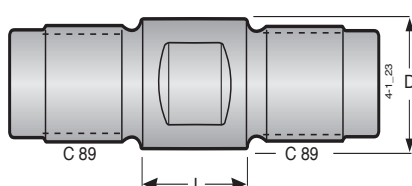

100	-	3 15/16"	103	4 1/16"	7989-6003
100	-	3 15/16"	103	4 1/16"	7989-6203 ¹⁾

Wrench flat 90 mm. ¹⁾ With cutting outlet

Foundation drilling tools

OD 72 (3 1/2"), for BBE 56/57

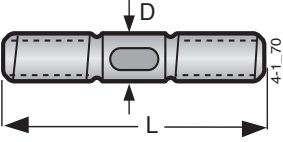
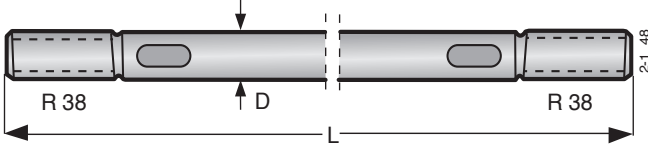
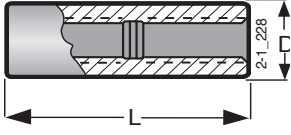
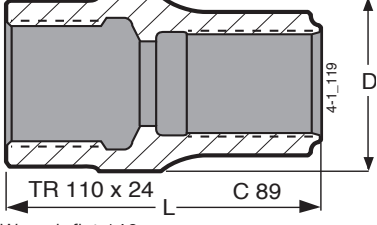
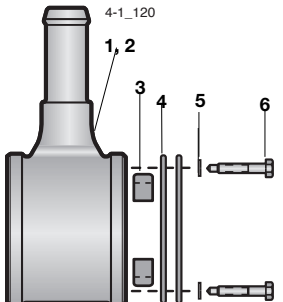
	Dimensions			D		Part No.
	L			mm	in	
	mm	ft	in			
Extension, R38 - Round 39 - R38						
	280	-	11 1/32"	39	1 1/2"	7854-4302-20
Extension rod, R38 - Round 39 - R38						
	1220 3050	4' 10'	- -	39 39	1 1/2" 1 1/2"	7854-4312-30 7854-4331-30
Wrench flat 32 mm.						
Coupling sleeve, R38						
	170	-	6 11/16"	55	2 5/32"	7994-3655
Adapter sleeve, C89						
	260	-	10 1/4"	150	5 7/8"	7989-6650
Wrench flat 140 mm.						
Flushing device, hose connection 38 mm (1 1/4")						
	109	-	4 9/32"	-	-	7982-6000
Complete						7982-6001
1. Flushing head						795-1804
2. Packing (2 per unit)						7982-6002
3. Locating ring						7982-6003
4. Lock ring						7982-6004
5. Spring washer (4 per unit)						7982-6005
6. Screw (4 per unit)						

Foundation drilling tools

OD 72 (3 1/2"), for BBE 56/57

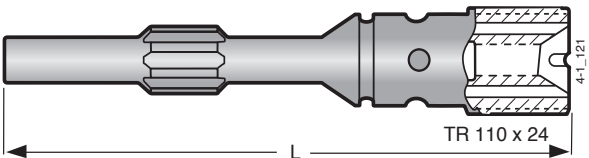
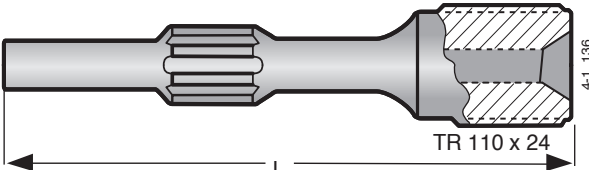
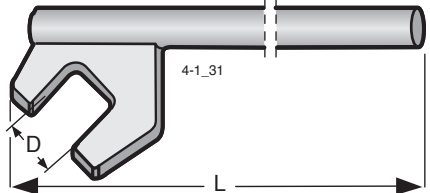
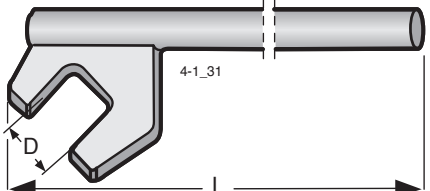
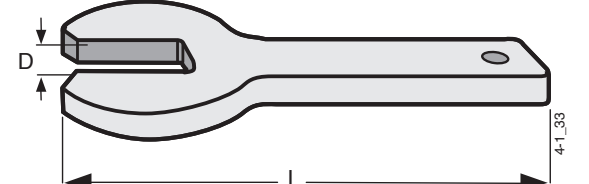
	Dimensions			D		Part No.	
	L			mm	in		
	mm	ft	in				
Shank adapter, for separate flushing							
 <p>For rock drill BBE 56U2 and BBE 57-01. Flushing tube 14 (9/16").</p>	Thread	633	–	24 7/8"	–	–	7981-7003
Shank adapter, for central flushing							
 <p>Flushing tube 14 (9/16").</p>	Thread	520	–	20 15/32"	–	–	7981-7004 Packing 795-1821
Wrench for tube coupling							
		700	2'	3 9/16"	90	3 35/64"	795-1443
Wrench for adapter sleeve							
		700	2'	3 9/16"	140	5 1/2"	795-1445
Wrench for extension rod							
		370	1'	2 9/16"	32	1 1/4"	795-1432

Foundation drilling tools

OD 92 (4 3/8"), for BBE 56/57

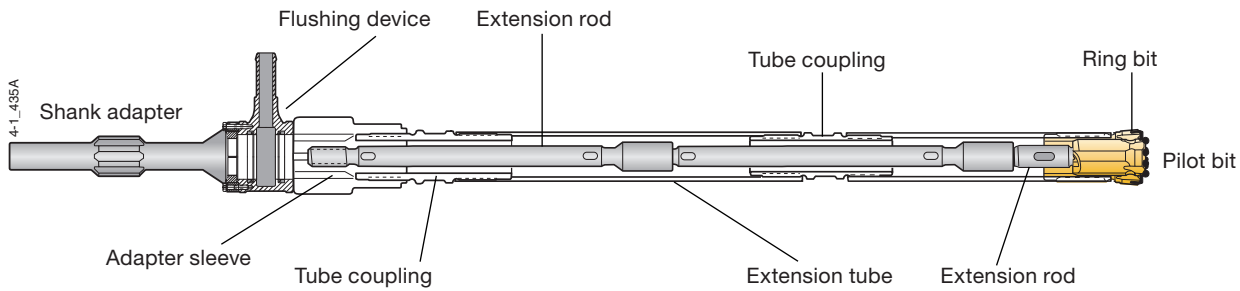

Flushinghole, mm		Buttons, mm		Dimensions		Part No.
Front	Gauge	Front	Gauge	D		
No Size	No Size	No Size	No Size	mm	in	

Pilot bit, T45, button bit

		3x10	-	5x10	9x11	35°	89	3 1/2"	7515-7889-R55
--	--	------	---	------	------	-----	----	--------	---------------

Pilot bit, T45, x-bit

		1	7.5	2	7.5	-	-	-	89	3 1/2"	7515-4489-11
--	--	---	-----	---	-----	---	---	---	----	--------	--------------

Ring bit, C110

		-	-	-	-	-	131	5 5/32"	7588-6531-42
		-	-	-	12x12	35°	131	5 5/32"	7588-9531-B45

Dimensions			Part No.	
L	D		mm	in
mm	ft	in	mm	in

Extension tube

		1100	3'	7 5/16"	124	4 7/8"	7985-6112
		2930	9'	7 23/64"	124	4 7/8"	7985-6131

Tube coupling

	120	-	4 47/64"	124	4 7/8"	7989-6103
	120	-	4 47/64"	124	4 7/8"	7989-6503 ¹⁾

Wrench flat 110 mm. ¹⁾ With cutting outlet.

Foundation drilling tools

OD 92 (4 3/8"), for BBE 56/57

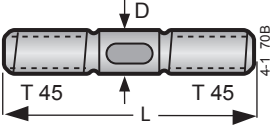
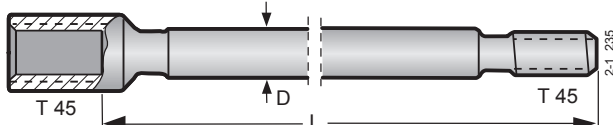
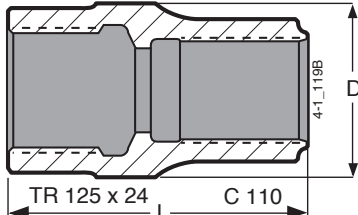
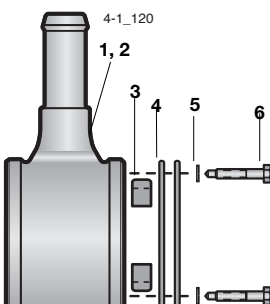
	Dimensions			D		Part No.	
	L	ft	in	mm	in		
Extension, T45 - Round 46 - T45							
	Thread						
	T45	280	–	11 1/32"	46	1 3/4"	7325-7302-21
MF-rod T45 - Round 46 - T45							
		3050	10'	–	46	1 3/4"	7325-7731E-28
Flushing hole 18 Ø mm. Female end OD 71 mm. Two wrench flats.							
Adapter sleeve, C110							
		285	–	11 7/32"	150	5 7/8"	7989-6752
Wrench flat 155 mm							
Flushing device, hose connection 38 mm (1 1/4")							
	Complete	109	–	4 9/32"	–	–	7982-6000
1. Flushing head							7982-6001
2. Packing (2 per unit)							795-1804
3. Locating ring							7982-6002
4. Lock ring							7982-6003
5. Spring washer (4 per unit)							7982-6004
6. Screw (4 per unit)							7982-6005

Foundation drilling tools

OD 92 (4 3/8"), for BBE 56/57

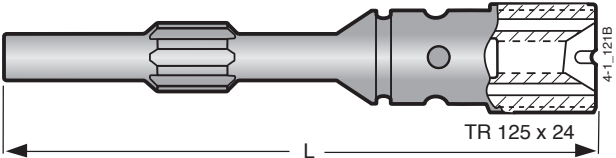
	Dimensions			D		Part No.
	L	ft	in	mm	in	
Shank adapter, for separate flushing						
	633	–	24 7/8"	–	–	7981-7009

For rock drill BBE 56U2 and BBE 57-01.

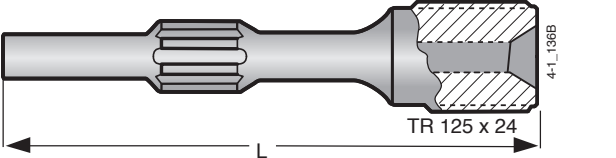
Shank adapter, for central flushing						
	520	–	20 15/32"	–	–	7981-7008
						Packing 795-1821

Flushing tube 14 (9/16").

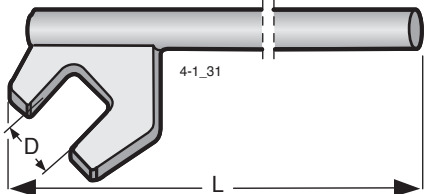
Wrench for tube coupling	700	2'	3 9/16"	110	4 21/64"	795-1483
						

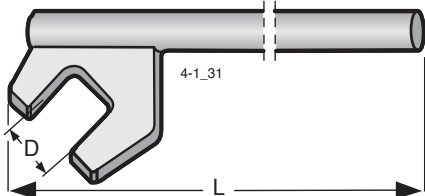
Wrench for adapter sleeve	700	2'	3 9/16"	155	6 1/8"	795-1446
						

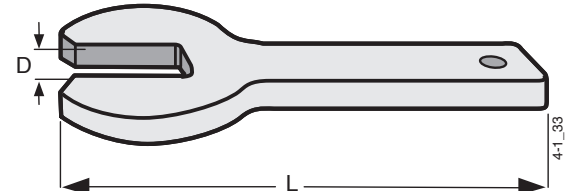
Wrench for extension rod	370	1'	2 9/16"	32	1 1/4"	795-1432
						

Foundation drilling tools

TUBEX 76/127 eccentric drilling tools for top hammers

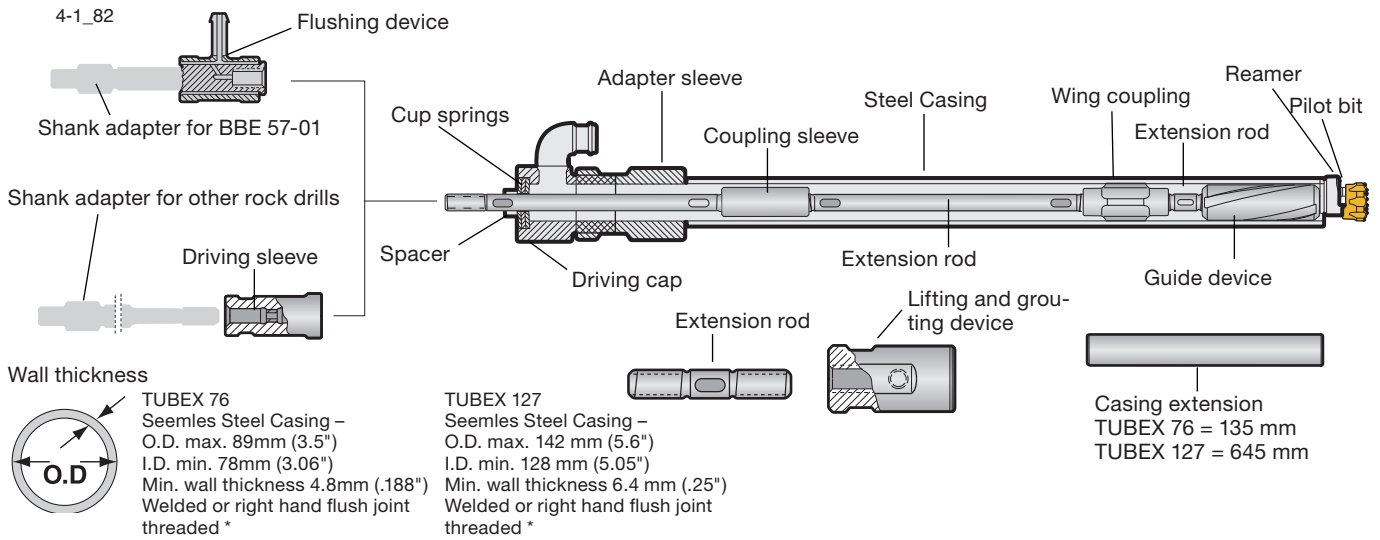

TUBEX	Flushing hole, mm		Buttons, mm		Angle	Dimensions		Part No.
	Front No	Gauge size	Front No	Gauge Size		D mm	in	

Pilot bit									
	76	1x6	2x6	5x10	6x12	35°	70	2 3/4"	7588-0570-40
	127	2x10	–	8x12	8x14	35°	110	4 21/64"	7588-0310-40

Eccentric reamer, button bit DP 60									
	76	–	2x5	–	3x10	30°	77	3 1/32"	7588-0596-60
	Reaming Dia.						96	3 25/32"	
	127	–	2x5	2x12	3x14	35°	125	4 31/32"	7588-0362-60
	Reaming Dia.						162	6 3/8"	

TUBEX	Dimensions			D mm	in	Part No.
	L mm	ft	in			

Guide device							
	Thread						
	R38	76	270	–	10 5/8"	76 3"	7989-1577
	R51	127	270	–	10 5/8"	127 5"	7989-1326

Extension rod							
	Thread						
	R38 – R38	76	280	–	11"	39 1 1/2"	7854-4302-20
	R51 – R51	127	770	2'	6 5/16"	52 2"	7855-5308-30

* Welded casing to be bought locally. Threaded casing delivered upon request.

Foundation drilling tools

TUBEX 76/127 eccentric drilling tools for top hammers

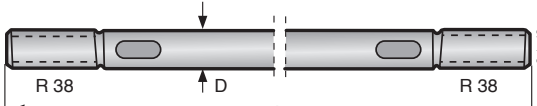
	Thread	TUBEX	Dimensions			D		Part No.
			L	ft	in	mm	in	
Extension rod								
	R38 – R38	76/127	1220	4'	–	39	1 1/2"	7854-4312-30
	R38 – R38	76/127	1830	6'	–	39	1 1/2"	7854-4318-30
	R38 – R38	76/127	2435	8'	–	39	1 1/2"	7854-4324-30
	R38 – R38	76/127	3050	10'	–	39	1 1/2"	7854-4331-30

Flushing hole Ø 15 mm. Wrench flat 32 mm.

Wing coupling

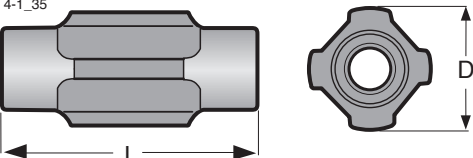
	R38 – R38	76	180	–	7 1/16"	76	3"	7994-3076
	R38 – R51	127	205	–	8 5/64"	127	5"	7994-4727

Coupling sleeve

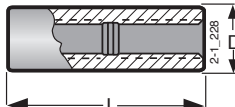
	R38 – R38	76/127	170	–	6 11/16"	55	2 5/32"	7994-3655
---	-----------	--------	-----	---	----------	----	---------	------------------

Adapter sleeve for threaded equipment

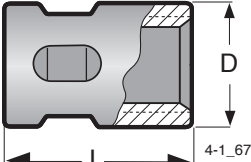
	76	200	–	7 7/8"	118	4 41/64"	7989-1508
	127	200	–	7 7/8"	170	6 11/16"	7989-1370

Adapter sleeve for welded equipment

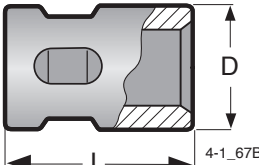
	76	200	–	7 7/8"	118	4 41/64"	7989-1513
	127	200	–	7 7/8"	170	6 11/16"	7989-1360

Driving cap, hose connection 63.5 (2 1/2")

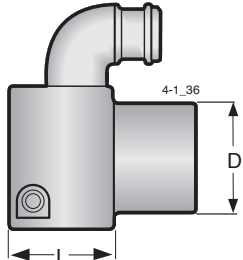
	76	138	–	5 1/2"	94	3 45/64"	7989-1544*
	127	138	–	5 7/16"	144	5 43/64"	7989-1390*
	Outlet tube separate 76/127						



* Outlet tube 7982-0001 included

Cup spring (3 pcs required) 80x40x5

	1 piece	76/127	–	–	–	–	–	795-2010
--	---------	--------	---	---	---	---	---	-----------------

Foundation drilling tools

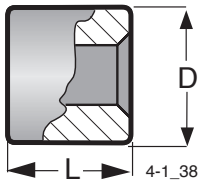
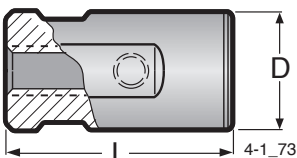
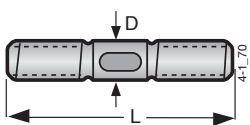
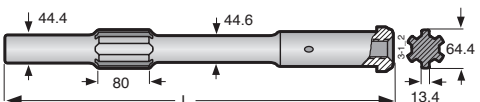
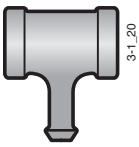
TUBEX 76/127 eccentric drilling tools for top hammers

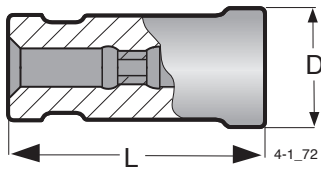
	Thread	TUBEX	Dimensions			D mm	in	Part No.
			L mm	ft	in			
Spacer								
		76/127	62	–	2 7/16"	81	3 3/16"	7989-1505
Lifting and grouting device								
		76	210	–	8 17/64"	108	4 1/4"	7989-1509
Extension rod for lifting- and grouting device								
		76	280	–	11"	39	1 1/2"	7854-4302-20
Shank Adapters for BBE 57-01								
	R38	76/127	537	1'	9 9/64"	44.4	1 3/4"	7804-7505-01 ¹⁾
Flushing device, hose connection 25.4 (1")								
								7801-0001 Packing (2 pieces req.) 795-1806
Shank Adapter for other machines, with central flushing or built-in separate flushing, male thread R38, T38 or T45								
		76/127						See page 63
Driving sleeve for shank adapters with male thread R38, T38 or T45								
	R38 – R38		199	–	7 27/32"	83	3 17/64"	7989-1512
	T38 – R38		199	–	7 27/32"	83	3 17/64"	7989-1519
	T45 – R38		205	–	8 5/64"	83	3 17/64"	7989-1517

Wrench flat 65 mm.

¹⁾ Split stop ring required (machine part).

Foundation drilling tools

TUBEX XL90/115 eccentric drilling tools for top hammers. With casing shoe

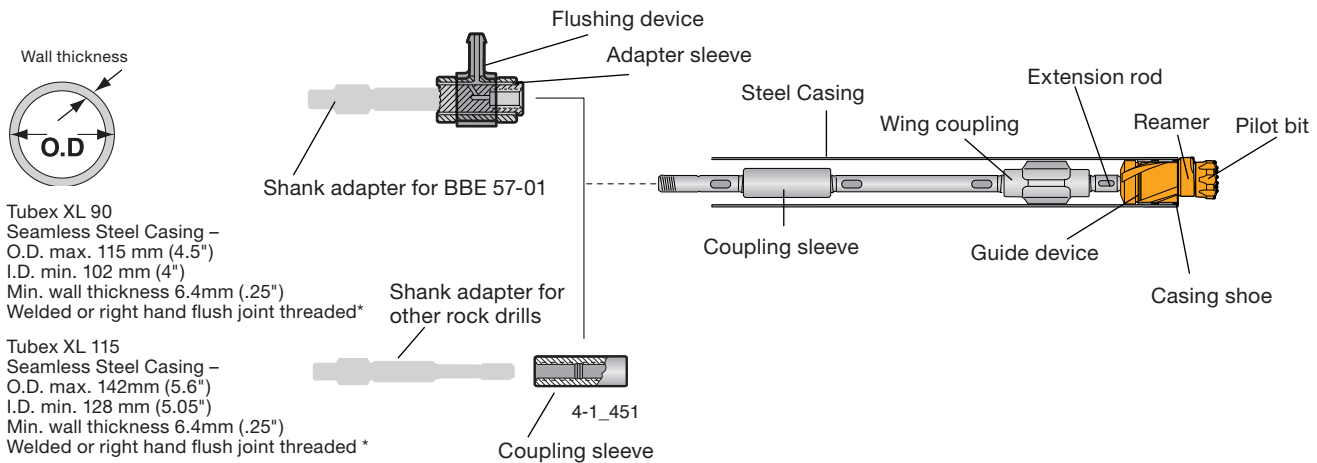

Tubex XL 90
Seamless Steel Casing –
O.D. max. 115 mm (4.5")
I.D. min. 102 mm (4")
Min. wall thickness 6.4mm (.25")
Welded or right hand flush joint threaded*

Tubex XL 115
Seamless Steel Casing –
O.D. max. 142mm (5.6")
I.D. min. 128 mm (5.05")
Min. wall thickness 6.4mm (.25")
Welded or right hand flush joint threaded *

TUBEX	Flushing hole, mm		Buttons, mm		Angle	Dimensions		Part No.
	Front No size	Gauge No Size	Front No Size	Gauge No Size		D mm	in	

Pilot bit



XL90	1x12	3x8	6x12	8x12	35°	90	3 35/64"	81-090L-090A60
115	2x10	–	8x12	8x14	35°	110	4 21/64"	7588-0310-40

Eccentric reamer

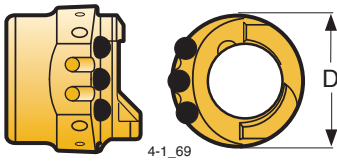

XL90	–	–	–	3x12	35°	90	3 35/64"	82-090L-123A60
Reaming Dia.						123	4 27/32"	
115	–	2x5	2x12	3x14	35°	115	4 33/64"	7588-5452-40
Reaming Dia.						152	6 1/8"	

Thread	TUBEX	Dimensions			D mm	in	Part No.
		L mm	ft	in			

Casing shoe

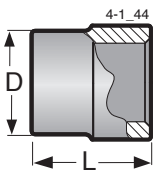

–	XL90	80	–	3 1/8"	101	3 31/32"	84-090D-00
–	115	150	–	5 29/32"	127.5	5 1/64"	7989-1603-10

Guide device

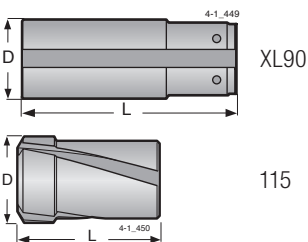

T51	XL90	275	–	10 13/16"	100	3 15/16"	80-9700-090D
R51	115	270	–	10 5/8"	126	4 61/64"	7989-1616-10

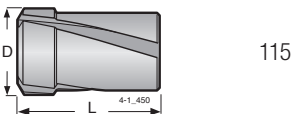

Extension rod

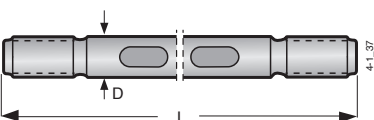

T51 – T51	XL90	770	2'	6 5/16"	52	2"	7326-5308C-30
R51 – R51	115	770	2'	6 5/16"	52	2"	7855-5308-30

* Welded casing to be bought locally. Threaded casing delivered upon request

Foundation drilling tools

TUBEX XL90/115 eccentric drilling tools for top hammers. With casing shoe

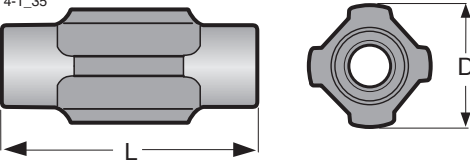
	Thread	TUBEX	Dimensions			D	in	Part No.
			L	ft	in			
Wing coupling								
	T45 – T51	XL90	215	–	8 15/32"	100	4 21/64"	7316-6200
	T51 – T51	XL90	220	–	8 21/32"	100	4 21/64"	7316-6300
	R51 – T45	115	215	–	8 15/32"	127	5"	7315-4727
	R51 – T51	115	220	–	8 21/32"	127	5"	7316-4727

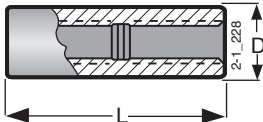
Coupling sleeve								
	T45 – T45	XL90/115	210	–	8 1/8"	63	2 31/64"	7315-3363
	T51 – T51	XL90/115	225	–	8 7/8"	71	2 51/64"	7316-3671

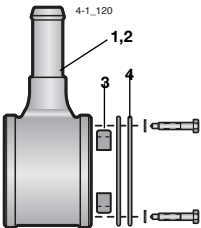
Flushing device, hose connection 38 mm (1 1/2")								
	Complete	XL90/115	109	–	4 9/32"	–	–	7982-6000
	1) flushing head							7982-6001
	2) Packing (2 per unit)							795-1804
	3) Locating ring							7982-6002
	4) Lock ring							7982-6003
	5) Spring washer (4 per unit)							7982-6004
6) Screw (4 / unit)							7982-6005	

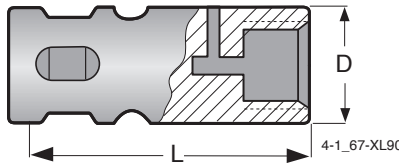
Adapter sleeve for separate flushing device								
	T45 – T45	XL90/115	335	–	13 9/16"	89	3 1/2"	7989-1230
	T51 – T51	XL90/115	335	–	13 9/16"	89	3 1/2"	7989-1240

Pilot bit pin								
	1 piece	XL90	44	–	1 47/64"	9.85	25/64"	795-6020-00

Self-locking spring pin								
	1 piece	XL90	15	–	19/32"	10	13/32"	795-2001-08

Pusher for pilot bit pin								
	1 piece	XL90	115	–	4 17/32"	7	9/32"	795-2552

Locking Balls (8 pieces req.)								
	1 piece	XL90	–	–	–	9.5	3/8"	795-6021-00