

# Sandvik DC302R

## Surface Top Hammer Drills



Sandvik DC302R is a fully remote controlled, hydraulic and self-propelled drilling unit on a 4-wheel, oscillated drive carrier.

Typical applications for DC302R are foundation drilling, road cutting, trenching, occasional bolting and other special drilling applications. Therefore DC302R is most often used by construction contractors, mines and quarries, and the municipal sector. Due to its versatility DC302R is often included in the equipment fleet of rental houses as well.

Hole Diameter:	64 mm (1 ½" - 2 ½")
Rock Tools:	25, 28 or 32 mm (1", 1 ⅛" or 1 ¼") rods
Rock Drill:	8 kW
Engine Output:	61 kW
Flushing Air:	2,5 m <sup>3</sup> /min, up to 8 bar
Production Capacity:	500 - 950 m <sup>3</sup> /8h
Total Weight	5 300 kg

## STANDARD COMPONENTS

Rock drill	HL 300, hydraulic
Chain feed	CF 300 x 12/Pito 9H, incl. one set of jaws
Rod rack	For 2 extra rods on chain feed
Boom	DB 300, articulated
Carrier	Rubber-tyred
Powerpack	Diesel driven, hydraulic pumps and on-board compressor
Hydraulic system	Open center and load sensing
Control system	TA 342, remote controlled
Dust collector	DC 410H, hydraulic
Working lights	4 pcs
Hydraulic jacks	4 pcs
Manuals	Service and spare parts manuals: 1 x paper copy 1 x CD-ROM (Toolman)

## SELECTION OF OPTIONS

1.	HEX 1 rock drill (replaces standard component)
2.	Hydraulic winch (2 tons)
3.	Pulling device for 22 mm (7/8") rods
4.	Chain tracks
5.	Hydraulic drill steel grinder, Dynaset
6.	Hydraulic drill steel grinder for integral steels, Sandvik RG100H
7.	Angle indicator MEC Angie
8.	TIM 2104 Tamrock inclination angle measuring and controlling system
9.	Electric filling pump for refuelling
10.	Electric engine heater
11.	Spirit level angle indicator

## THE JAWS FOR DRILL STEELS

Drill steel type	Drill steel diameter	Recommended hole diameter
Hexagonal rod for HEX 1 drifter	22 mm 7/8"	28 - 45 mm 1 7/64" - 1 3/4"
Extension rods	25 mm 1"	38 - 45 mm 1 1/2" - 1 3/4"
Extension rods	28 mm 1 1/8"	38 - 48 mm 1 1/2" - 1 7/8"
Extension rods	32 mm 1 1/4"	45 - 64 mm 1 3/4" - 2 1/2"

If several jaws selected please specify jaws assembled.

12.	Hydraulic roll-over (360°) boom head Specify the boom head dead point - upwards - 3 o'clock from front
13.	Bigger rotation motor (400 Nm) for 51 or 64 mm holes
14.	PTX exhaust gas purifier
15.	Water flushing kit without water pump
16.	Water pump for water flushing kit
17.	Extra manuals
18.	First service kit for DC302R, ID 551 623 25
19.	Special tools for HL 300 field kit, ID 881 537 69

**COVERAGE AREA**

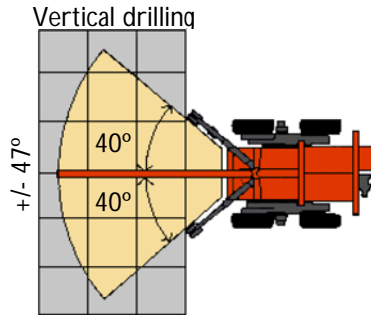
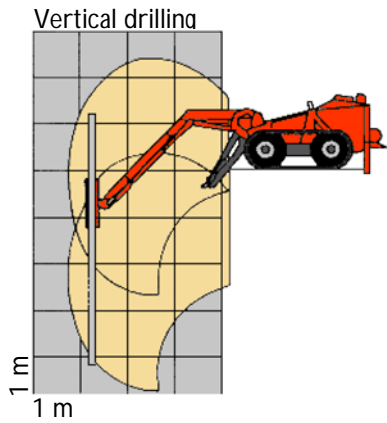

Horizontal drilling, forwards with manual roll-over

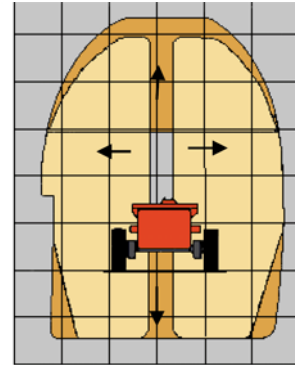

Horizontal drilling, sideways

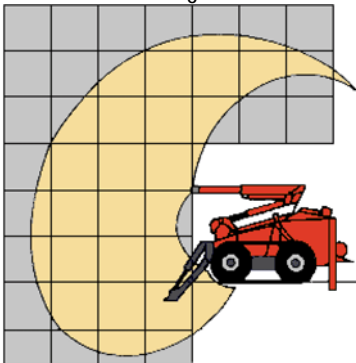

Bolting

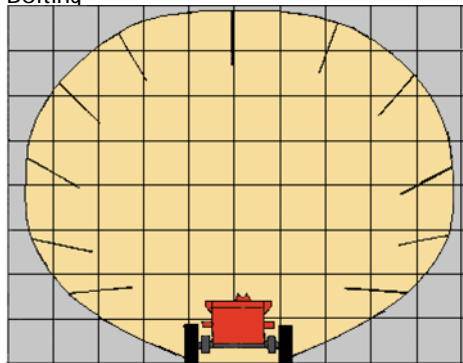

**TRAMMING AND TRANSPORT DIMENSIOS**

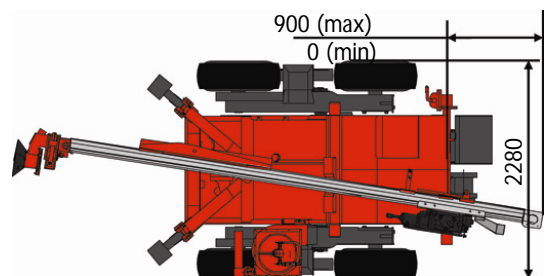
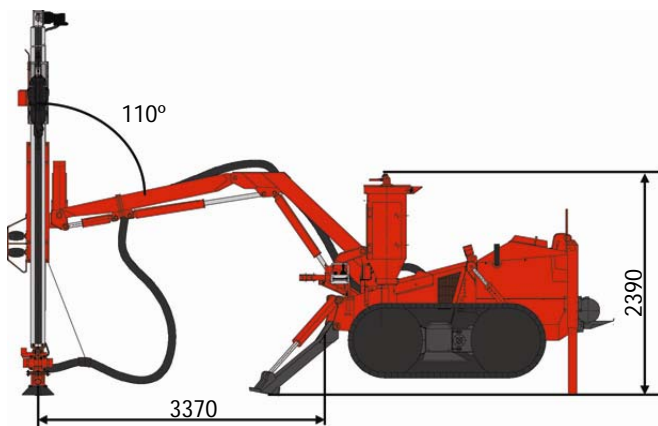

Weight (without options)	5 300 kg
Width without tracks	2.3 m
Height	2.6 m
Total length	5.6 m