

HX410 electrostatic dust suppression





Dust suppression in bulk material conveying systems

ECONOMICAL, EFFECTIVE, LOW-MAINTENANCE

In many industrial areas dust problems which adversely affect not only the conveying process but also the people and the surroundings arise during bulk material conveyance. A substantial amount of the material is lost through the formation of dust.

HX410 is a new, ionization-based dust suppression system which was developed particularly for controlling dust problems during bulk material conveyance. HX410 is economical, effective, low-maintenance and offers an excellent alternative to traditional dust removal systems.

The HX410 electrostatic dust suppression system was designed to bind dust where it is formed and to return it to the process. It is a simple system with very low operating and maintenance costs.

Inactive system

Active system

Specification

EFFECTIVELY AND INDIVIDUALLY DIMENSIONED

The separation capacity of the HX410 is largely independent of the particle size, but as in all electric filters it is dependent on the flow rate or the retention time of the dust in the filter.

HX410 collects dust particles ranging in size from 0.01 µm to > 300 µm (300 µm = 0.3 mm).

The HX410 electrostatic dust suppression system was designed especially for conveyor belt systems. However, it can be used with other bulk material conveying systems as well.

DIMENSIONING

The adjoining drawing and the table show the main dimensions of the basic systems for different belt widths.

For a more exact dimensioning of the HX410 system we ask you to specify the dimensions according to the drawing on the left or to send us a drawing of the considered conveyor.

In addition to the accompanying basic data, we require information on the material to be handled and the operating conditions. A separate questionnaire is available for this.

TECHNICAL DATA (MIF 4 BASIC SYSTEM)

- Current feed:
 - single phase 230 V, 10 A
- Operating/control information:
 - closing contact
- Grounding:
 - 6 mm² to the equipotential busbar
- Length of the dust housing:
 - 2000 - 8000 mm which can be lengthened/shortened in modules of 1000 mm
- Supporting structure of the dust housing:
 - standard and customized
- Connection:
 - customized design according to the existing system

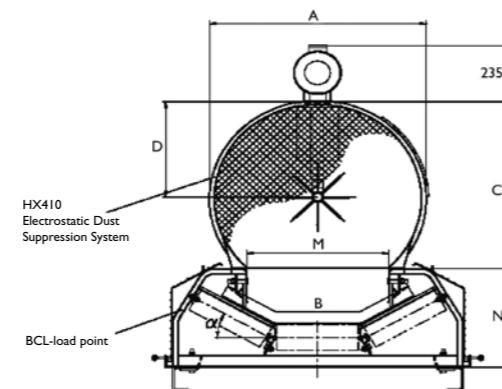

Main dimensions and space requirements of the basic system

B	A	C	D	M			N		
				30°	45°	20°	30°	45°	20°
500	500	480	250	310	280	320	382	400	389
650	600	540	285	420	400	440	400	435	412
800	790	710	395	550	490	570	420	448	445
1000	860	720	415	720	640	740	450	499	420
1200									
1400									
1600									

For belt widths over 1000 mm the dust binding system is always dimensioned according to the application.

Fields of Application/ Experience

FIELDS OF APPLICATION

The HX410 electrostatic dust suppression system is suitable for many bulk materials particularly at material transfer points in stationary and mobile conveyor belts in the following industries:

- quarries, sand & gravel
- mining industry
- steel industry
- cement industry
- glass industry
- foundries
- paper

ADVANTAGES OF THE SYSTEM

- guaranteed dust suppression > 90 %
- minimum material loss
- no suction/filter or sprinkling
- no disposal costs
- no wear and tear
- low power requirement < 500 W
- low-maintenance – no qualified staff required
- very low operating costs
- modular design
- short mounting and commissioning time
- no modification in the material properties

CONVINCING COST EFFECTIVENESS

Wear or consequential costs for other plant components always result in increased maintenance and operating costs in all conventional dust suppression methods used at material delivery points. But that's not true with HX410!

Convince yourself of the cost effectiveness of Sandviks HX410 electrostatic dust suppression system in the adjoining table.

OVERVIEW OF COST FACTORS

Operating costs due to	suction	sprinkling	HX410
wear	☹	☹	☺
filter	☹	☺	☺
filter change	☹	☺	☺
filter disposal	☹	☺	☺
pipng	☹	☹	☺
chemicals	☺	☹	☺
water	☺	☹	☺
electrical energy	☹	☹	☹
frost risk	☹	☹	☺
consequential costs for other systems	☹	☹	☺
servicing	☹	☹	☹
energy costs Euro/1000 t	> 0,1	> 0,25	< 0,03

☺ no operating costs
☹ operating costs



Application potash mining



Functional principle/ Mode of operation

FUNCTIONAL PRINCIPLE

The HX410 electrostatic dust suppression system was designed and developed for use at material transfer points of belt conveying systems. The functional principle is that of an electrostatic filter. It is based on the physical principle of separation by ionization.

MODE OF OPERATION

The system has a modular design and is installed directly behind the conveyor belt transfer point above the conveyor belt. The transported material and dust are conveyed through the dust suppression housing where the dust is separated by electrostatic forces in the HX410 housing. An intermittently starting unbalance motor at the housing of the apparatus returns the dust to the material flow.

SIMPLE AND ECONOMICAL

The HX410 electrostatic dust suppression system features a simple design. It is easy to install in new as well as already existing bulk material conveying systems.

The HX410 system is equipped with a high voltage unit, control unit, high voltage insulator, corona electrodes and the protective housing surrounding the dust suppression point. The operating voltage of the system is 230 V and energy consumption is only a few hundred watts. The maintenance and operating costs are low because the system does not have any moving parts and no special maintenance or operational staff is required.

Sandvik is a high-technology engineering group with world-leading positions in selected areas – tools for metal working, advanced materials technology, and mining and construction. We are represented in 130 countries.

Sandvik Mining and Construction represents one third of the overall Sandvik Group and serves a broad range of customers in construction, mineral exploration, mining and bulk materials handling. Our construction expertise covers quarrying, tunneling, demolition and recycling, and other civil engineering applications. Our mining products and services support customers on the surface and under ground, in all mineral, coal and metal mining applications from exploration to ore transportation.

