

Cutting Attachment MA520 in Action

Fully proved in various applications

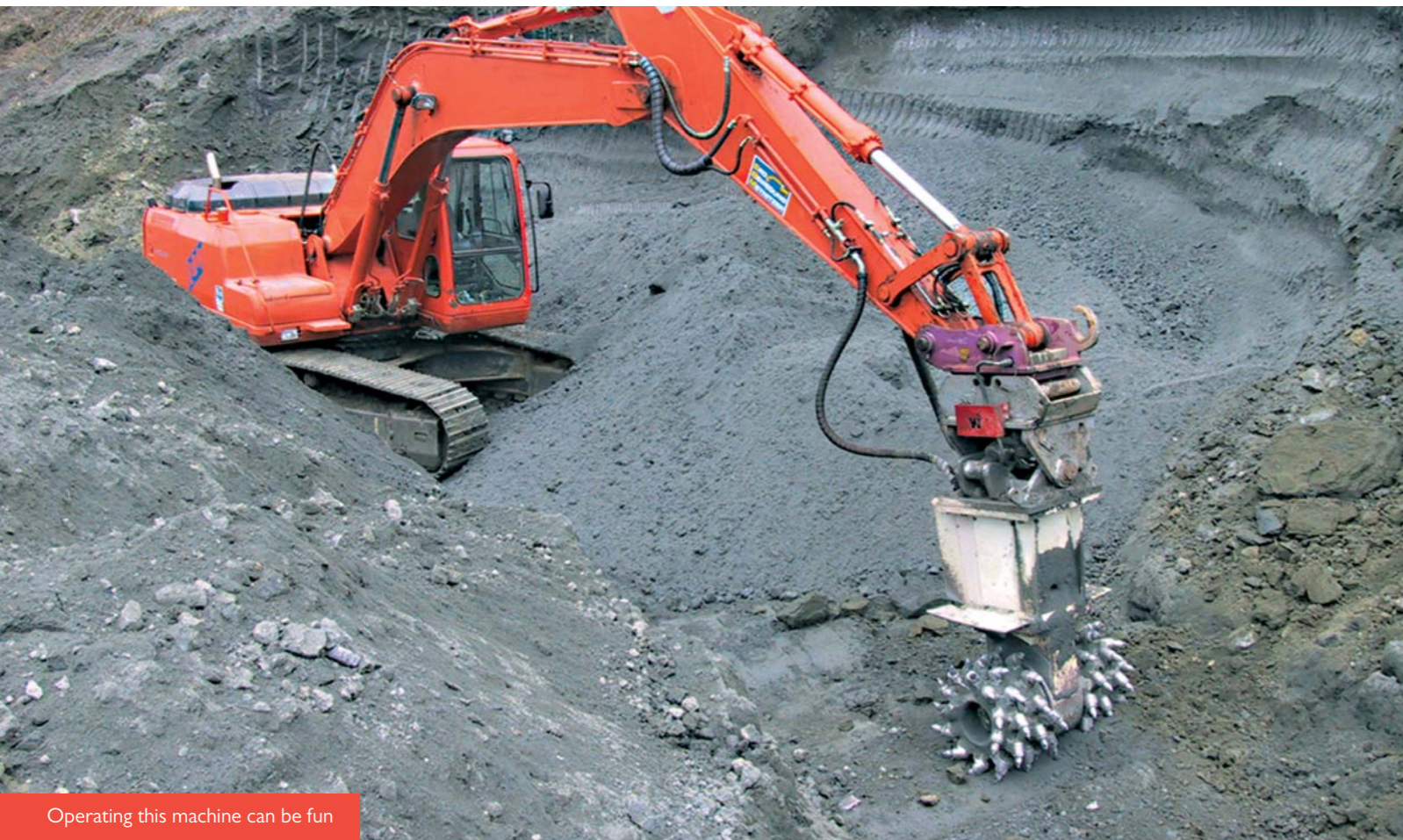



Operating this machine can be fun

Sandvik Cutting Attachment MA520

The hydraulic cutting unit as an attachment for hydraulic excavators is an ideal complementary tool to close the gap between shovel and hammer/breaker or ripper.

Technical data MA520*

Technical Data Hydraulic (supplied by the excavator)

Oil pressure**	320 bar	4640 psi
Oil flow**	188 l/min	49.60 usgal/min
Recommended Diesel Power	min. 100 kW	min. 134 hp

Technical Data Cutting Unit***

Output torque	11.065 Nm	97.936 lbfin
Output speed	86,30 min ⁻¹	86,30 min ⁻¹
Cutter head diameter	700 mm	27,56 in
Cutting force	31.615 N	7.107 lbf
Cutting speed	3,2 m/s	126 in/s
Weight of cutting unit	2.140 kg	4.720 lb

Recommended Carrier Weight	>20 t	>44.080 lb
-----------------------------------	-------	------------

- * All rights for technical modification are reserved
- ** Independent from other moves of the boom
- *** Dependent on the hydraulic supply of the excavator



From vision to reality

Unique features of the MA520

- Compact design
- Optimized cutterhead design based on 40 years experience in Roadheader business
- Rigid housing made of alloy steel (casted)
- Size of cut material for further use
- Ideal tool to extend the range of application of an excavator

Sandvik Cutting Attachment MA520

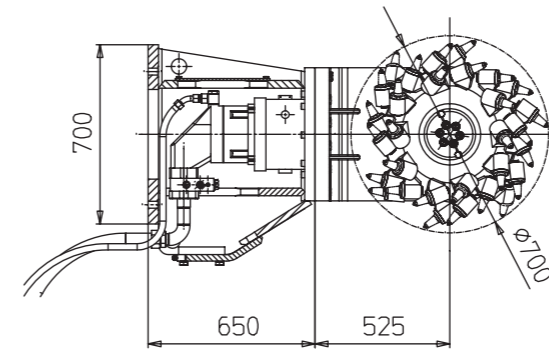

Wide use of applications:

- Excavation of large profiles
- Excavation in partial cross sections
- Demolition works
- Trenching
- Profiling and scaling
- Enlargement of tunnels
- Production (e.g. gypsum quarries)
- Planning of paved areas
- Suitable for underwater application
- Mixing of soil (with cement)
- Stump cutting

Short changing times by use of:

- Quick changer
- Hydraulic quick coupling

