

Sandvik Jaw Crushers





Excellent durability thanks to welded frame.



Range including models for mobile applications.

The product of decades of experience

At Sandvik we have over a century of experience of designing and manufacturing jaw crushers. We also have a wealth of knowledge about customers' expectations and needs. This background has led to the current range of Sandvik jaw crushers which includes models specially suited for mobile applications. Strength has been increased and weight has been reduced. Sandvik's jaw crushers provide an excellent choice when high production and low total cost are sought.

ROBUST CONSTRUCTION

The Sandvik jaw crusher is a single toggle jaw crusher, characterized by attention to detail, in both design and manufacture. We have incorporated the best of the old and applied the benefits of the latest technology.

The frame consists of two side plates of rolled steel, plus hollow castings at front frame end and moving jaw which give a high rigidity/weight ratio. Large-radius transition areas reduce stress concentrations and welds are positioned in low-stress areas.

The advantage of a welded frame is that it is equally strong in all directions and ensures excellent durability against shock-loads. Thus minimizing the risk of failure on the main-frame, as with a bolted construction.

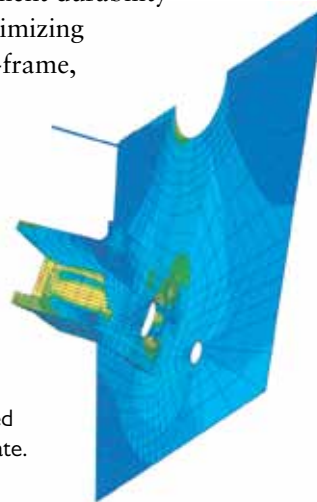

FEA (Finite element analysis) printout showing the predicted stress distribution in a side plate.

SANDVIK JAW CRUSHER

Symmetrical crushing chamber.
Effective feed opening = Nominal feed opening.

COMPETITOR

Conventional crushing chamber.
Effective feed opening < Nominal feed opening.

SANDVIK JAW CRUSHER

A deflector plate at the top of the moving jaw means that no intrusive cross-wall is required in the feed hopper. All of the effective feed opening is active. Material is crushed right at the top of the crushing chamber.

COMPETITOR

Cross-wall required in feed hopper to protect top of moving jaw. Stationary cross-wall reduces effective feed opening. Material cannot be crushed until it has dropped a good distance into the crushing chamber.

Effective feed opening

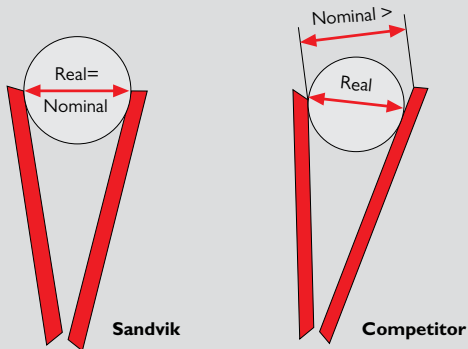

Active feed opening

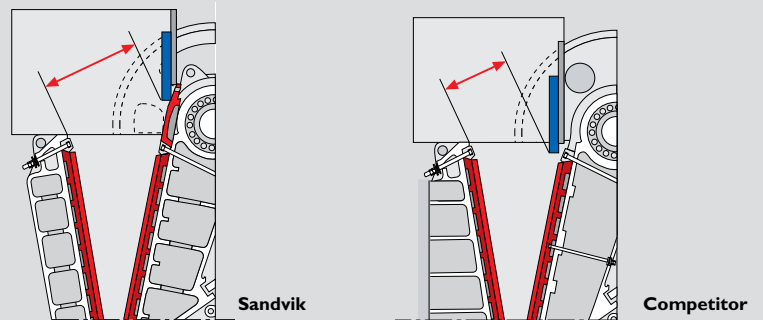

OPTIMIZED PERFORMANCE

- High capacity
- High reduction
- Low jaw plate wear
- Large feed acceptance capability

These four factors are closely linked and the Sandvik jaw crusher provides a good balance.

The design of the deep symmetrical crushing chamber maximizes feed size, capacity and reduction.

An optimized nip angle ensures that the material progresses smoothly down through the crushing chamber to enable high reduction, productivity and superb utilization of jaw plates.

It is not just a large nominal feed opening that is necessary – the feed acceptance capability depends on a feed opening which is effective and active (see illustration). All crushers in the range have an almost square feed opening so that they can accept the largest material lumps without blockages.

A thick, replaceable deflector plate protects the top of the moving jaw from the impact of the feed material. Large material lumps entering the crusher fall straight into the active region of the crushing chamber, so there is no need for a stationary cross-wall in the feed area.

MAINTENANCE FRIENDLINESS IN FOCUS

Thanks to carefully engineered design, Sandvik's jaw crushers secure trouble-free operation and increased uptime.

- Bearings are grease-lubricated and have grease-filled labyrinth seals to prevent the entry of dust.
- As a standard, grease lubrication hoses with a central distribution block offer safety value and make it easier for the operator to grease the bearings.
- Automatic lubrication system that can be connected to existing control systems for remote alarm indication ensuring protection of the roller bearings.
- Setting adjustment made with traditional shim plates.
- Quick and easy installation of jaw plates by using clamping and support bars to fix the jaw plates to the crusher.
- Designed with sacrificial parts to protect the main components of the crusher such as frame, swing jaw and bearings. This reduces total life-cycle costs and increases uptime, as it is less expensive to change the sacrificial parts than the main components.

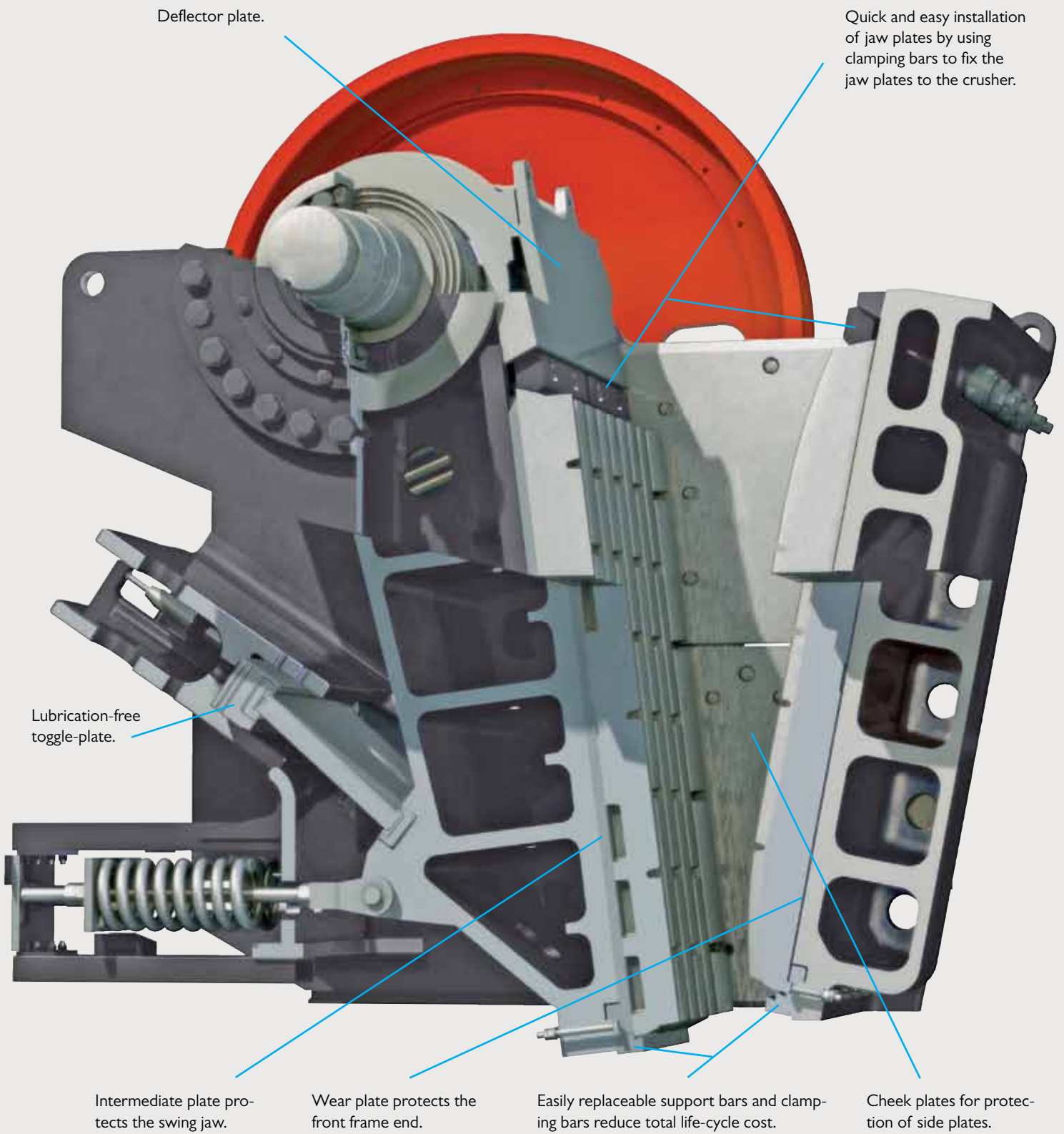

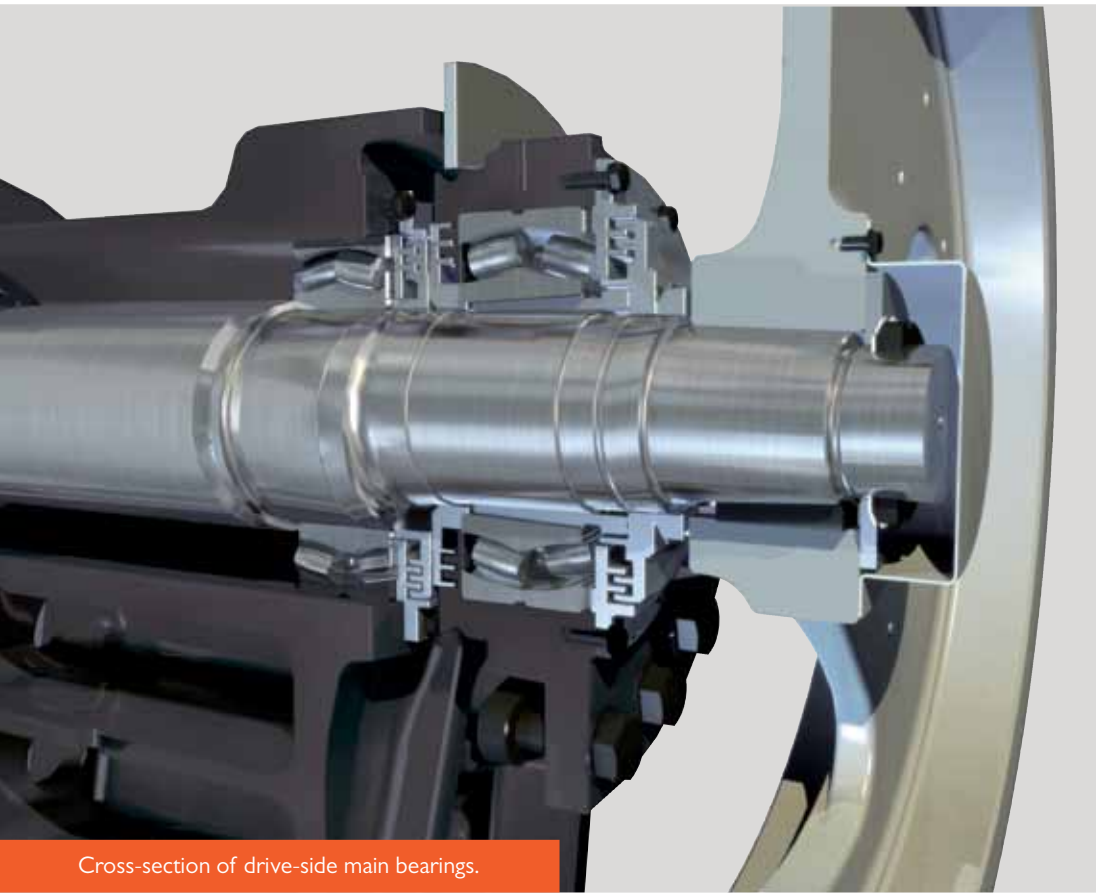

Cross-section of drive-side main bearings.

MULTIPLE ADVANTAGES

Robust with low weight.

Increased uptime thanks to operator friendly design.

Uniform welded construction.

High capacity and high reduction.

Effective, active feed opening.

Jaw plates for all types of applications.

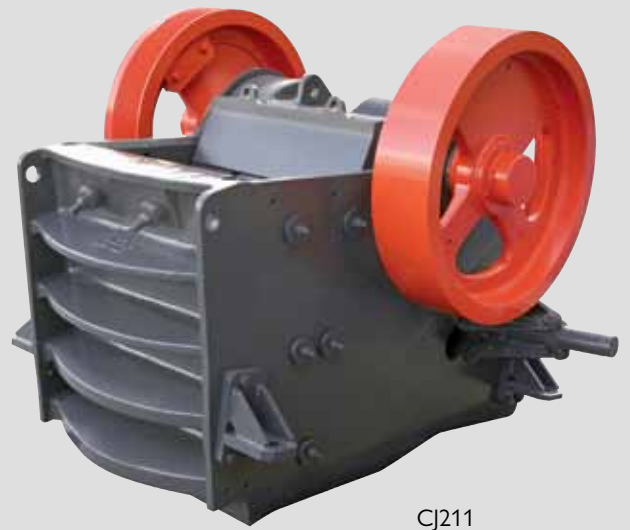

CJ211



WT: Wide Teeth

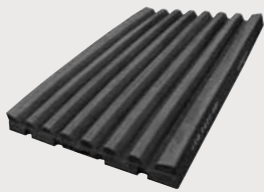

CC: Coarse Corrugated

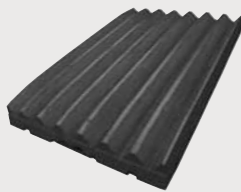

ST: Sharp Teeth



HD: Heavy Duty

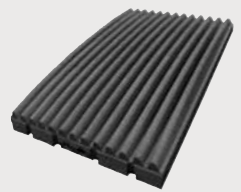

C: Corrugated



Protect your business... and your bottom line

HIGH PERFORMANCE, COST-EFFECTIVE CRUSHING CHAMBERS

At Sandvik we have engineered rock crushers since 1896. Sandvik crushing chamber solutions are based on high-quality products with superior finish, supported by indepth knowledge of every aspect in the crushing process.

Our mission is to work together with our customers to achieve the optimal crushing chamber application in terms of performance, cost-effectiveness and results.

VERSATILE RANGE OF JAW PLATES

Sandvik's wear parts are designed to give high performance and low operating costs. High quality material and experienced design ensure quality parts. Fine tuning in applications are ensured through the available range of alternative jaw plate designs.

All jaw plates are reversible. The "WT" jaw plate can also be used on both the stationary and moving jaw.

SUPPORT WHERE AND WHEN IT COUNTS

For most people, service is a matter of being available when problems occur. But we at Sandvik prefer seeing it as a matter of being proactive. Investment in, for instance, scheduled inspections and maintenance will help you protect your business from unexpected risks.

Moreover, availability of essential parts and consumables, efficient and quick logistical processes, fully trained operators... all these ensure trouble-free operations and maximize productivity.

Performance data

Product curves

The figure shows product distribution curves which are representative for medium-hard material [Impact Work Index (Wi = 16)], with approx. 75% of the product smaller than the crusher's Closed Side Setting (CSS).

The shape of the product curve and the proportion of the product which will be smaller than the CSS depend on the characteristics of the feed material. Operation with common rock materials with different crushabilities (Work Index between 12 and 20) normally results in a product curve that is between 65% and 85% smaller than the crusher's CSS.

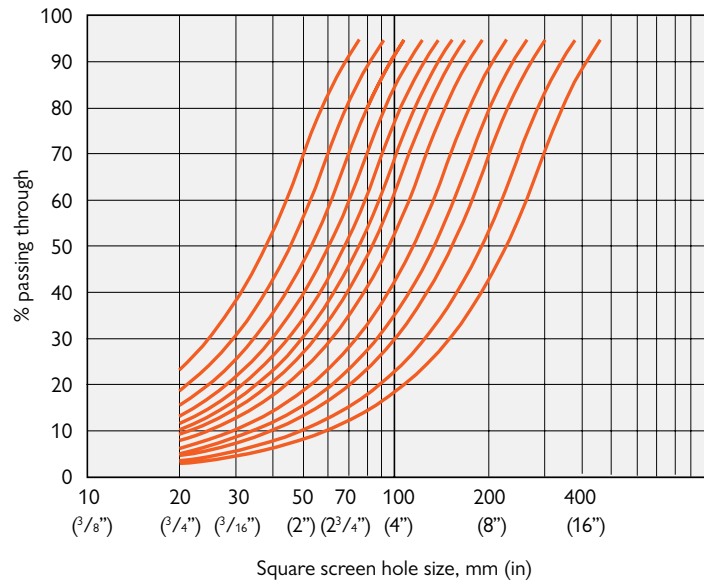

Capacity MTPH (STPH)

Closed side setting (CSS)		Crusher model							
		CJ211	CJ409	CJ411	CJ412	CJ612	CJ613	CJ615	CJ815
mm	in								
40	1 5/8	80-110 (90-120)							
50	2	95-135 (105-150)	85-115 (95-125)						
75	3	127-192 (140-212)	100-160 (110-175)	150-200 (165-220)	165-220 (180-245)				
100	4	160-250 (175-275)	125-200 (140-220)	200-265 (220-290)	220-290 (240-320)				
125	5	195-310 (215-340)	150-235 (165-260)	245-325 (270-360)	270-355 (300-390)	300-395 (330-435)	330-430 (365-475)	385-495 (425-545)	
150	6	230-370 (250-410)	175-275 (195-305)	295-390 (325-430)	325-430 (360-475)	355-465 (390-515)	385-505 (425-555)	445-590 (490-650)	480-625 (530-690)
175	7	265-430 (290-475)	200-320 (220-350)	340-445 (375-490)	385-505 (425-555)	405-530 (445-585)	440-575 (485-635)	505-665 (555-735)	545-710 (600-785)
200	8	300-490 (330-540)		385-505 (425-555)	445-580 (490-640)	455-595 (500-655)	495-650 (545-715)	570-745 (630-820)	610-800 (675-880)
225	9			430-565 (475-625)	495-650 (545-715)	505-660 (555-730)	550-730 (605-805)	630-825 (695-910)	675-885 (745-975)
250	10				550-720 (605-795)	560-735 (615-810)	605-810 (670-895)	700-920 (770-1015)	745-975 (820-1075)
275	11				605-790 (665-870)	610-805 (670-890)	660-885 (730-975)	765-1000 (845-1100)	820-1070 (905-1180)
300	12						715-960 (790-1060)	(825-1085) (910-1195)	885-1160 (975-1280)

The capacity figures given in the table above are approximate and are intended only to give an indication of what the crushers can be expected to produce. They apply for the open-circuit crushing of dry blasted granite with a bulk density of 1600 kg/m³ (100 lbs/ft³) and a maximum size which can be fed into the crushing chamber without difficulty. The lower values apply for a feed from which the material finer than the crusher's CSS has been removed. The higher values apply for a feed which includes the fine material. The minimum CSS at which the crusher can be operated depends on the feed size distribution, the material's crushability (Wi), the degree of contamination and moisture in the feed, the type of jaw plates fitted and the condition of the manganese.

CJ211

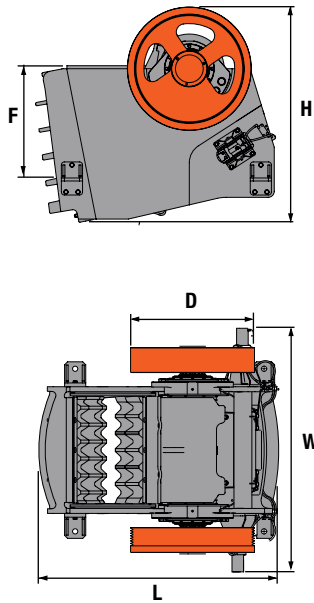

CJ400/600/800-series

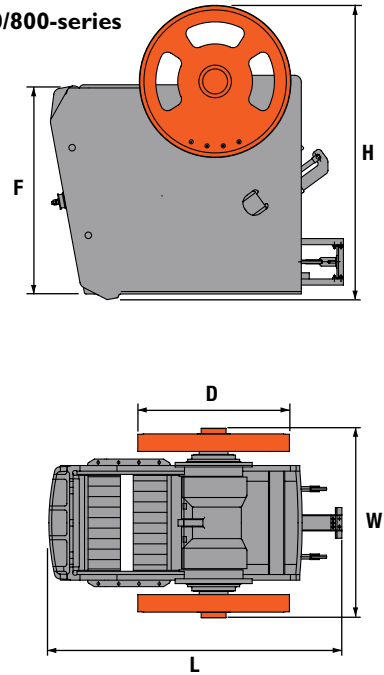

Other data

	Crusher model							
	CJ211	CJ409	CJ411	CJ412	CJ612	CJ613	CJ615	CJ815
Feed opening mm in	1100x700 43x27	895x660 35x28	1045x840 41x33	1200x830 47x33	1200x1100 47x43	1300x1130 51x45	1500x1070 59x42	1500x1300 59x51
L = Max length m in	2.39 94	2.55 101	2.99 118	3.23 127	3.61 142	3.76 148	4.11 161	4.50 177
W = Max width m in	2.45 96	1.88 74	2.09 82	2.57 101	2.35 92	2.47 97	3.00 118	2.90 108
H = Max height m in	2.17 86	2.38 94	2.82 111	2.95 116	3.51 138	3.85 152	3.33 131	4.19 165
D = Flywheel diam. m in	1.23 48	1.60 63	1.86 74	1.86 74	1.86 74	2.17 86	1.76 70	2.17 86
F = Feed height m in	1.12 44	1.58 62	1.88 74	1.93 76	2.50 98	2.68 105	2.39 94	3.05 120
Shipping volume m ³ ft ³	14.1 498	13 447	20 704	23 810	32 1127	38 1329	48 1690	58 2042
CSS min-max mm in	40-200 1.6-7.9	50-175 2-7	75-225 3-9	75-275 3-11	125-275 5-11	125-300 5-12	125-300 5-12	150-300 6-12
Total weight kg lbs	15000 33100	14500 32000	22000 48500	27000 59500	39000 86000	44000 97000	54000 119100	64500 142200
Motor power kW hp	90 125	75 100	110 150	132 200	160 250	160 250	200 275	200 275
Crusher speed rpm	270	270	240	240	210	225	200	200

Sandvik is a global industrial group with advanced products and world-leading positions in selected areas – tools for metal cutting, equipment and tools for the mining and construction industries, stainless materials, special alloys, metallic and ceramic resistance materials as well as process systems. In 2011 the Group had about 50,000 employees and representation in 130 countries, with annual sales of more than 94,000 MSEK.

Sandvik Construction is a business area within the Sandvik Group providing solutions for virtually any construction industry application encompassing such diverse businesses as surface rock quarrying, tunneling, excavation, demolition, road building, recycling and civil engineering. The range of products includes rock tools, drilling rigs, breakers, bulk-materials handling and crushing and screening machinery. In 2011 sales amounted to more than 9,000 MSEK, with approximately 2,600 employees (pro forma rounded numbers).

