

Small hole drilling



Small hole drilling

	Page
H19 (3/4) Integral drill steels	5
H22 (7/8") Integral drill steels	6
Reaming tools	7
H22 Tapered tools, 12° taper.....	8
H22 Tapered tools, 11° taper.....	9
H22 Tapered tools, 7° taper	10
Stone working tools.....	11
R22 (7/8") Extension drilling tools	12
R23 (29/32") Extension drilling tools	13
R25 (1") Extension drilling tools.....	14
Sandvik Alpha. α 250 bit thread	15

Small hole drilling

H19 (3/4") Integral drill steels

H19 (3/4")

Series	Dimensions D					Part No.
	L mm	ft	in	D mm	in	

Shank 19 x 108 mm (3/4" x 4 1/4")

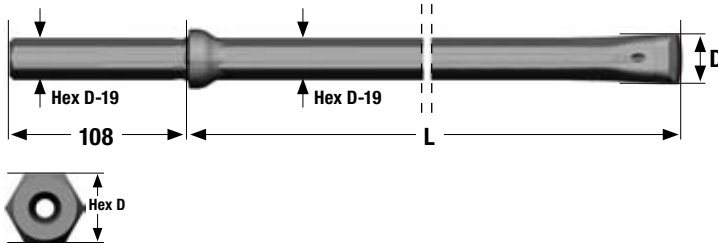

21	400	1'	4"	29	1 9/64"	724-0429
-	800	2'	7"	28	1 7/64"	724-0828
-	1600	5'	3"	27	1 1/16"	724-1627
-	2400	7'	10"	26	1 1/32"	724-2426
24	600	2'	-	27	1 1/16"	724-0627
-	1200	3'	11"	26	1 1/32"	724-1226
Boulder-steel	400	1'	4"	24	15/16"	724-0424
	800	2'	7"	23	29/32"	724-0823

Shank 22 x 108 mm (7/8" x 4 1/4")

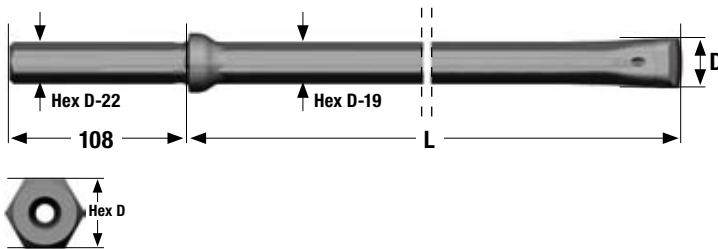

	400	1'	4"	24	15/16"	728-0424
	400	1'	4"	29	1 9/64"	728-0429
	800	2'	7"	28	1 7/64"	728-0828
	1600	5'	3"	27	1 1/16"	728-1627

Small hole drilling

H22 (7/8") Integral drill steels

H22 (7/8")

	Dimensions D						Part No.
	Series	L mm	ft	in	D mm	in	
Shank 22x108 mm (7/8" x 4 1/4")							
	11	800	2'	7"	34	1 11/32"	714-0834-65
		1600	5'	3"	33	1 19/64"	714-1633-65
		2400	7'	10"	32	1 1/4"	714-2432-65
		3200	10'	6"	31	1 7/32"	714-3231
		4000	13'	1"	30	1 3/16"	714-4030
		4800	15'	9"	29	1 9/64"	714-4829
		5600	18'	4"	28	1 7/64"	714-5628-50
		6400	21'	–	27	1 1/16"	714-6427-50
		7200	23'	8"	26	1 1/32"	714-7226-50
		12	800	2'	7"	40	1 37/64"
		1600	5'	3"	39	1 17/32"	714-1639-65
		2400	7'	10"	38	1 1/2"	714-2438-65
		3200	10'	6"	37	1 29/64"	714-3237-65
		4000	13'	1"	36	1 27/64"	714-4036-65
		4800	15'	9"	35	1 3/8"	714-4835-65
		5600	18'	4"	34	1 11/32"	714-5634-65
		6400	21'	–	33	1 19/64"	714-6433-65
		7200	23'	8"	32	1 1/4"	714-7232-65
	13	400	1'	4"	34	1 11/32"	714-0434-65
		800	2'	7"	33	1 19/64"	714-0833-65
		1200	3'	11"	32	1 1/4"	714-1232-65
		1600	5'	3"	31	1 7/32"	714-1631
		2000	6'	7"	30	1 3/16"	714-2030
	16	600	2'	–	35	1 3/8"	714-0635-65
		1200	3'	11"	34	1 11/32"	714-1234-65
		1800	5'	11"	33	1 19/64"	714-1833-65
		2400	7'	10"	32	1 1/4"	714-2432-65
	17	600	2'	–	41	1 5/8"	714-0641-65
		1200	3'	11"	40	1 37/64"	714-1240-65
		1800	5'	11"	39	1 17/32"	714-1839-65
		2400	7'	10"	38	1 1/2"	714-2438-65
		2000	6'	7"	33	1 19/64"	714-2033-65
		8000	26'	3"	26	1 1/32"	714-8026-50
		8800	28'	11"	25	1"	714-8825-5005
		9600	31'	6"	25	1"	714-9625-5005
		800	2'	7"	29	1 9/64"	714-0829
		1600	5'	3"	28	1 7/64"	714-1628-50
		2400	7'	10"	27	1 1/16"	714-2427-50

Small hole drilling

H22 Reaming tools

	Dimensions D					Part No.
	L	ft	in	D	in	
Pilot rod, Hex 22, 6° taper	mm			mm		
	800	2'	7 1/2"	26	1 1/32"	7922-6108-11
	1200	3'	11 3/4"	26	1 1/32"	7922-6112-11
	2000	6'	6 3/4"	26	1 1/32"	7922-6120-11
	2500	8'	2 1/2"	26	1 1/32"	7922-6124-11

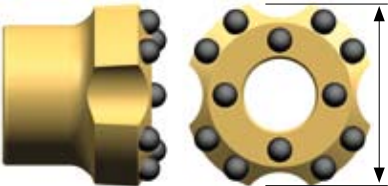
	Buttons, mm		Angle	Dimensions D		Part No.
	Front No Size	Gauge No Size		mm	in	
Reaming tools for cut holes / Reaming bit, 6° taper						
	4x8	8x9	25°	64	2 1/2"	7722-4864-S45
	4x10	8x10	30°	76	3"	7722-4876-S45
	6x10	8x10	30°	89	3 1/2"	7722-4889-S45

Small hole drilling

H22 Tapered tools, 12° taper

H22 -12°

Bits	Flushinghole, mm		Buttons, mm		Angle	Dimensions D		Part No.
	Front No Size	Gauge No Size	Front No Size	Gauge No Size		mm	in	
Button bit								
	1x5	1x5	1x7	4x7	35°	28	1 1/8"	7795-6428-B48
	1x5	1x5	1x7	4x7	35°	30	1 3/16"	7795-6430-B48

Button bit								
	2x4	1x4	2x7	5x7	40°	32	1 1/4"	7795-5232-B48
	2x4	1x3,5	2x7	5x8	40°	35	1 3/8"	7795-5235-B48
	2x4	1x4	2x7	5x9	40°	38	1 1/2"	7795-5238-B48

Button bit								
	2x4	1x3.5	2x7	5x7	40°	33	1 9/64"	7770-5233-B48
	2x4	1x3.5	2x7	5x8	40°	35	1 3/8"	7770-5235-B48

Cross bit								
	1x4	2x4	-	-	-	30	1 3/16"	7770-9030-42
	1x6	2x4.5	-	-	-	32	1 1/4"	7770-9032-42
	1x6	2x4.5	-	-	-	35	1 3/8"	7770-9035-42

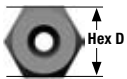
Rods		Dimensions D					Part No.
		L mm	ft	in	Hex D mm	in	
Tapered rod, shank 22x108, carburized							

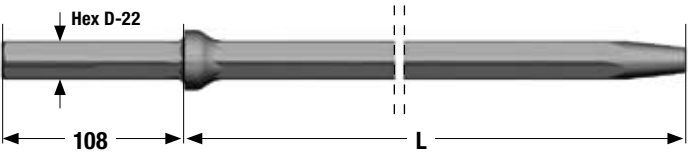
	610	2'	-	22	7/8"	7870-6106-11
	1220	4'	-	22	7/8"	7870-6112-11
	1830	6'	-	22	7/8"	7870-6118-11
	2000	6'	7"	22	7/8"	7870-6120-11
	2440	8'	-	22	7/8"	7870-6124-11
	3050	10'	-	22	7/8"	7870-6131-11
	3200	10'	6"	22	7/8"	7870-6132-11
	3660	12'	-	22	7/8"	7870-6137-11

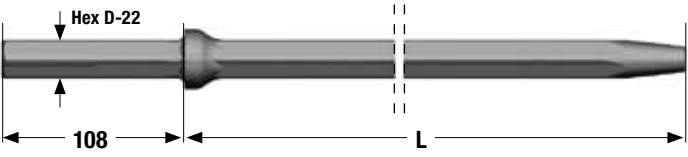
Tapered rod, shank 22x108, HF-hardened - For surface drilling						
	2440	8'	-	22	7/8"	7870-5124-11
	3200	10'	6"	22	7/8"	7870-5132-11
	4000	13'	1 1/2"	22	7/8"	7870-1140-11
	4400	14'	5"	22	7/8"	7870-1144-11
	4800	15'	9"	22	7/8"	7870-1148-11
	5600	18'	4 1/2"	22	7/8"	7870-1156-11
	6400	21'	-	22	7/8"	7870-1164-11
	7200	23'	7 1/2"	22	7/8"	7870-1172-11
	8000	26'	3"	22	7/8"	7870-1180-11
	8800	28'	10 1/2"	22	7/8"	7870-1188-11

Small hole drilling

H22 Tapered tools, 11° taper

H2 -11°

Bits	Flushinghole, mm		Buttons, mm		Angle	Dimensions D		Part No.
	Front No Size	Gauge No Size	Front No Size	Gauge No Size		mm	in	
Button bit								
	1x6	2x4	2x7	3x8	35°	32	1 1/4"	7776-1932-B48
	1x6	1x6	1x8	3x9	40°	36	1 7/16"	7776-1936-B48
	1x6	1x6	2x8	3x9	40°	38	1 1/2"	7776-1938-B48
	1x6	1x6	2x8	3x9	40°	40	1 3/8"	7776-1940-B48

Button bit								
	1x4	1x6	2x7	5x7	40°	32	1 1/4"	7776-4432-B48
	1x5	1x5	2x7	5x7	35°	35	1 3/8"	7776-4435-B48
	1x6	1x5	2x7	5x8	35°	38	1 1/2"	7776-4438-B48
	1x6	1x5	2x8	5x9	35°	40	1 3/8"	7776-4440-B48

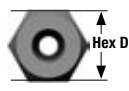
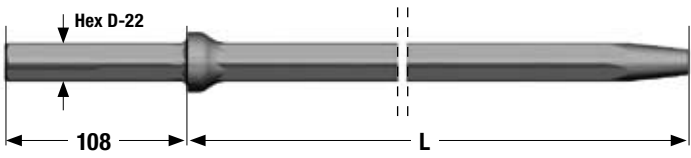
Rods		Dimensions D					Part No.
		L			Hex D		
Tapered rod, shank 22x108, carburized							
		mm	ft	in	mm	in	
	610	2'	–	22	7/8"	7876-6106-11	
	800	2'	7 1/2"	22	7/8"	7876-6108-11	
	1220	4'	–	22	7/8"	7876-6112-11	
	1830	6'	–	22	7/8"	7876-6118-11	
	2000	6'	7"	22	7/8"	7876-6120-11	
	2440	8'	–	22	7/8"	7876-6124-11	
	3050	10'	–	22	7/8"	7876-6131-11	
	3600	11'	9 1/2"	22	7/8"	7876-6136-11	

Small hole drilling

H22 Tapered tools, 7° taper

H22 - 7°

Bits	Flushinghole, mm		Buttons, mm		Angle	Dimensions D		Part No.
	Front No Size	Gauge No Size	Front No Size	Gauge No Size		mm	in	
Button bit								
	2x4	1x4	2x7	5x7	40°	32	1 1/4"	7788-5232-B48
	2x4	1x4	2x7	5x7	40°	33	1 9/64"	7788-5233-B48
	2x4	1x3.5	2x7	5x8	40°	35	1 3/8"	7788-5235-B48
	2x4	1x5	2x7	5x8	35°	38	1 1/2"	7788-5238-B48

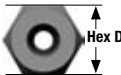
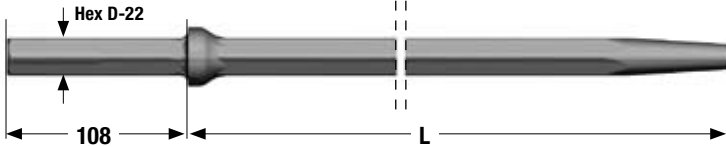
Rods		Dimensions D					Part No.
		L			Hex D		
Tapered rod, shank 22x108, carburized							
	2400	8'	–	22	7/8"	7888-6124-11	
	3200	10'	6"	22	7/8"	7888-6132-11	

Small hole drilling

Stone working tools

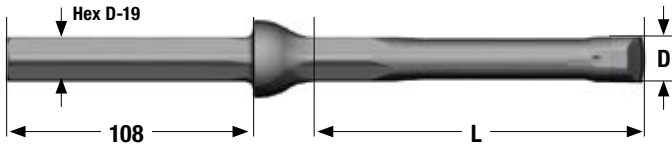
Plug hole integral steel	Dimensions D					Part No.
	L	mm		in		
	150	6"	17	21/32"	721-1517	
	160	6 1/4"	20	25/32"	721-1620	
	200	7 7/8"	20	25/32"	721-2020	
	240	9 29/64"	20	25/32"	721-2420	
	280	11 1/32"	20	25/32"	721-2820	
	310	11 1/4"	20	25/32"	721-3120	
	160	6 1/4"	22	7/8"	721-1622	
	190	7 1/2"	22	7/8"	721-1922	

Small hole drilling

R22 (7/8") Extension drilling tools

R22 (7/8")

Cross bit	Flushinghole, mm		Buttons, mm		Angle	Dimensions D		Part No.
	Front No Size	Gauge No Size	Front No Size	Gauge No Size		mm	in	
Cross bit	1	4.5	2	4.5	-	38	1 1/2"	7731-1038-42



Extension rod R22 - Hex 22 - R22	Dimensions D					Part No.
	L			D		
	mm	ft	in	mm	in	
	800	2'	7"	22	7/8"	7851-1308-20
	1200	3'	11"	22	7/8"	7851-1312-20
	1600	5'	3"	22	7/8"	7851-1316-20

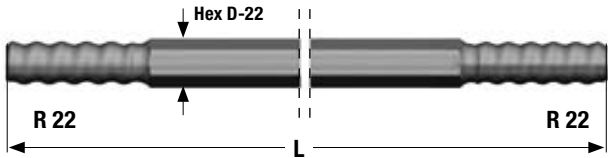
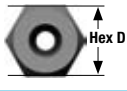

Shank adapter/Shank rod, Hex 22 - R22	Dimensions D					Part No.
	L	ft	in	D		
	255	-	10 3/64"	22	7/8"	7801-6103-13
	1000	3'	3"	22	7/8"	7801-6110-13

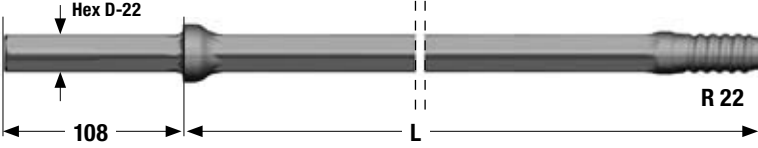

Coupling sleeve, R22	Dimensions D					Part No.
	L	ft	in	D		
	140	-	5 1/2"	31	1 7/32"	7991-2031



Small hole drilling

R23 (29/32") Extension drilling tools

R23 (29/32")

Bits	Flushinghole, mm		Buttons, mm		Angle	Dimensions D		Bit Classification	Part No.
	Front No Size	Gauge No Size	Front No Size	Gauge No Size		mm	in		
Button bit									
	1x4	1x6	2x7	5x7	35°	33	1 5/16"	HMCA	7737-4433-R48
	1x5	1x6	2x7	5x8	40°	35	1 3/8"	HMCA	7737-5235-R48
	1x6	1x6	2x7	5x8	35°	38	1 1/2"	HMCA	7737-4438A-R48
	1x5	1x6	2x8	5x9	35°	41	1 5/8"	HMCA	7737-5241-R48

Button bit									
	3x5	–	3x8	6x9	30°	45	1 3/4"	HMCA	7737-5345-R48

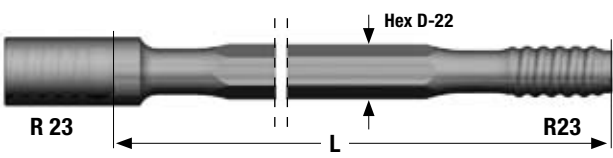
Rods	Dimensions D					Part No.
	L mm	ft	in	Hex D mm	in	
MF-rod, R23 - Hex 22 - R23						
 <p>Female end Ø 31 mm</p>	2095	6'	10 1/2"	22	7/8"	7857-4821-20
	3050	10'	–	22	7/8"	7857-4831-20

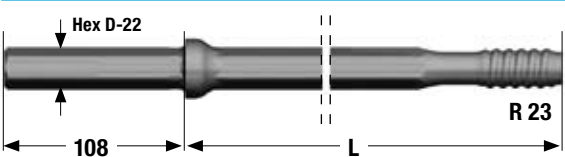

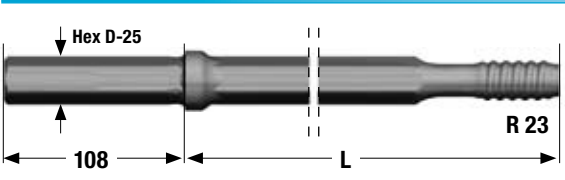
Shank adapter / Shank rod, Hex 22 - R23						
	255	–	10 3/64"	22	7/8"	7807-6103-11
	2400	8'	–	22	7/8"	7807-6124-11
	3200	10'	–	22	7/8"	7807-6132-11
	3600	11'	9 5/8"	22	7/8"	7807-6136-11

Shank rod, Hex 25 - R23						
	255	–	10 3/64"	25	1"	7807-7103-11
	3600	11'	9 "	25	1"	7807-7136-11

Small hole drilling

R25 (1") Extension drilling tools

R25 (1")

Bits	Flushinghole, mm		Buttons, mm		Angle	Dimensions D		Bit Classification	Part No.
	Front No Size	Gauge No Size	Front No Size	Gauge No Size		mm	in		
Button bit									
 	1x5	1x6	2x7	5x8	35°	35	1 3/8"	HMCA	7732-4435-S48
	1x5	1x6	2x7	5x9	30°	38	1 1/2"	HMCA	7732-5238-S48
	1x5	1x6	2x7	5x9	35°	38	1 1/2"	HMCA	7732-5238-R48
	1x5	1x6	2x8	5x9	35°	41	1 5/8"	HMCA	7732-5241-S48

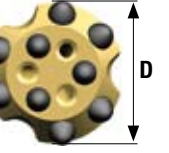

Button bit									
 	3x4.5	–	3x8	6x9	40°	45	1 3/4"	MSCFAN	7732-5345F-R48

Rods	Dimensions D					Part No.
	L mm	ft	in	Hex D mm	in	
Shank adapter / rod, Hex 22 x R25						
	255	–	10 3/64"	22	7/8"	7802-6103-13
	800	2'	7"	22	7/8"	7802-6108-13
	1000	3'	3"	22	7/8"	7802-6110-13

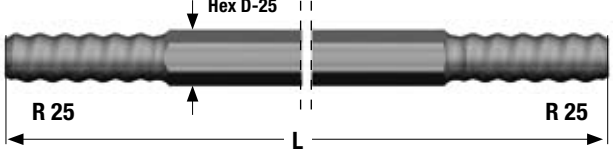
Extension rod, R25 - Hex 25 - R25						
	915	3'	–	25	1"	7852-2309-20
	1220	4'	–	25	1"	7852-2312-20
	1525	5'	–	25	1"	7852-2315-20
	1830	6'	–	25	1"	7852-2318-20
	2435	8'	–	25	1"	7852-2324-20
	3050	10'	–	25	1"	7852-2331-20

Coupling sleeve, R25						
	160	–	6 1/4"	35	1 3/8"	7992-2035

 - For one-rod drilling

Small hole drilling

Sandvik Alpha. α 250 bit thread

α 250

Bits	Flushinghole, mm		Buttons, mm		Angle	Dimensions D		Bit Classification	Part No.
	Front No Size	Gauge No Size	Front No Size	Gauge No Size		mm	in		

Button bit									
	1x5	1x6	2x7	5x8	40°	35	1 3/8"	HMCA	7764-5235-R48
	1x5	1x6	2x7	5x9	35°	38	1 1/2"	HMCA	7764-5238-R48

Button bit									
	3x4.5	–	3x8	6x9	40°	45	1 3/4"	MSCFAN	7764-5345F-R48

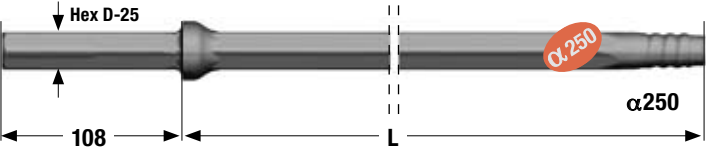
Rods	Dimensions D					Part No.
	L			Hex D		
Shank rod, Hex 25 - α 250						
	mm	ft	in	mm	in	
	3600	11'	9 5/8"	25	1"	7814-7136-11