

Reaming head

CRH 4

Reaming diameter

1420 mm

55 7/8"

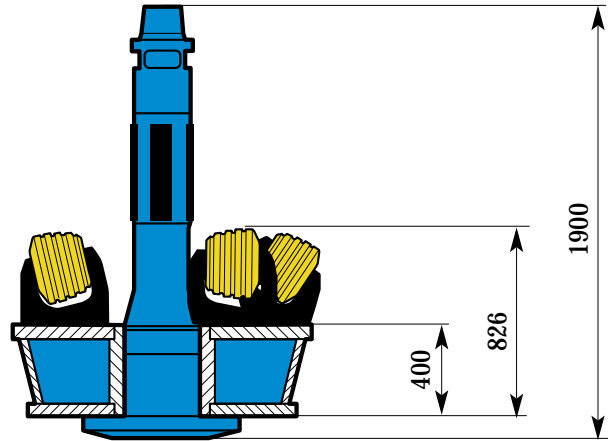
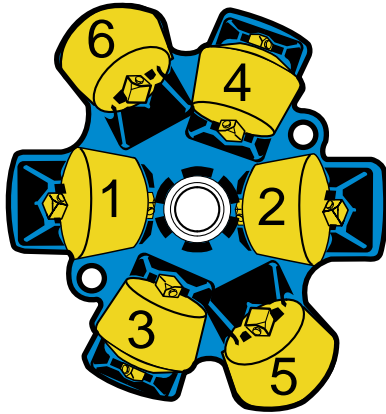

Reaming head	Pilot hole		Stem Part No.	Thread	Head Part No.		Saddles Pcs	Part No.
	in	mm			Without saddles	With saddles		
CRH 4	9	229	7008-3323-30	6 3/4" DI-22	7008-1314-20	7008-1314-31	1	7008-2013
	9 7/8	251	7008-3325-30				1	7008-2006
							2	7008-2005
							2	7008-2007
	11	279	7008-3428-30	8 1/4" DI-22	7008-1314-20	7008-1314-30	2	7008-2006
	12 1/4	311	7008-3431-30	8 1/4" DI-22			2	7008-2005
			7008-3531-30	9 1/4" DI-22			2	7008-2007
							2	

Reaming head	Required cutters for different spacing						
	Pilot hole in	Rock condition	Spacing mm in		Cutter Type	Cutter Part No.	Pcs
CRH 4	9-9 7/8	Soft to medium	51	2	CMR-41	7008-4141-76	3
					CMR-52	7008-4152-76	3
		Medium to hard	25.5	1	CMR-41	7008-4141-76	2
					CMR-52	7008-4152-76	4
	11-12 1/4	Soft to medium	51	2	CMR-41	7008-4141-76	2
					CMR-52	7008-4152-76	4
	Medium to hard	25.5	1	CMR-41	7008-4141-76	3	
				CMR-52	7008-4152-76	3	

Weights CRH 4	Kg	lb
	Stem 12 1/4"	1200
Head	1000	2200
Saddles	450	990
Cutters	600	1320
Total	3250	7160