

Reaming head CRH 2/2SP

Reaming diameter
660 mm
26 in

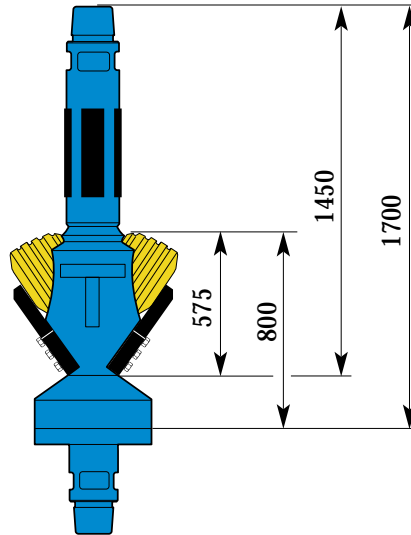
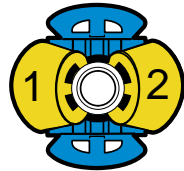

Reaming head Type	Pilot Hole		Integrated head and stem, Without saddles		Adapter	
	in	mm	Part No.	Thread diameter	Part No.	Thread diameter
CRH 2	9	228	7008-0306-2320	6 3/4" DI-22	-	-
	9 7/8	250	7008-0306-2520	6 3/4" DI-22	-	-
	11	279	7008-0406-2820	8 1/4" DI-22	-	-
	12 1/4	311	7008-0506-3120	9 1/4" DI-22	-	-
CRH 2SP	9	228	7008-0306-2325	6 3/4" DI-22	7008-9460	6 3/4" DI-22
	9 7/8	250	7008-0306-2525	6 3/4" DI-22	7008-9460	6 3/4" DI-22
	11	279	7008-0406-2825	8 1/4" DI-22	7008-9501	8 1/4" DI-22
	12 1/4	311	7008-0406-3125	8 1/4" DI-22	7008-9501	8 1/4" DI-22
	12 1/4	311	7008-0506-3125	9 1/4" DI-22	7008-9513	9 1/4" DI-22

Required cutters for different spacing					
Rock condition	Spacing		Cutter Type	Cutter Part No.	CRH 2/2SP Pcs
	mm	in			
Soft to medium	51	2	CMR-41	7008-4141-76	-
			CMR-52	7008-4152-76	2
Medium to hard	25.5	1	CMR-41	7008-4141-76	1
			CMR-52	7008-4152-76	1

Saddles CRH 2/2SP	
Pcs	Part No.
2	7008-2015

Weights CRH 2	Weights	
	Kg	lb
Head & stem	700	1540
Saddles (2 pcs)	100	220
Cutters (2 pcs)	250	550
Total	1050	2310

Weights CRH 2SP	Weights	
	Kg	lb
Head & stem	800	1760
Saddles (2 pcs)	100	220
Cutters (2 pcs)	250	550
Adapter	175	385
Total	1325	2915